Contents

Model

80DMLU62.2	100DMLU63.7	150DMLU65.5
80DMLU63.7	100DMLU65.5	150DMLU67.5
80DMLU65.5	100DMLU67.5	150DMLU611
80DMLU67.5	100DMLU611	150DMLU615
80DMLU611	100DMLU615	150DMLU622
80DMLU615	100DMLU622	
80DMLU622		

Section	Page
Specifications	902
Selection Chart	903
Performance Curves	904
Dimensions	908
Sectional View	911
QDC Information	1900
Motor Data	2000
motor electrical specifications	
cable data	
wiring diagrams	
motor electrical data	

EBARA Submersible Wastewater Pumps

DMLU

Model Designation

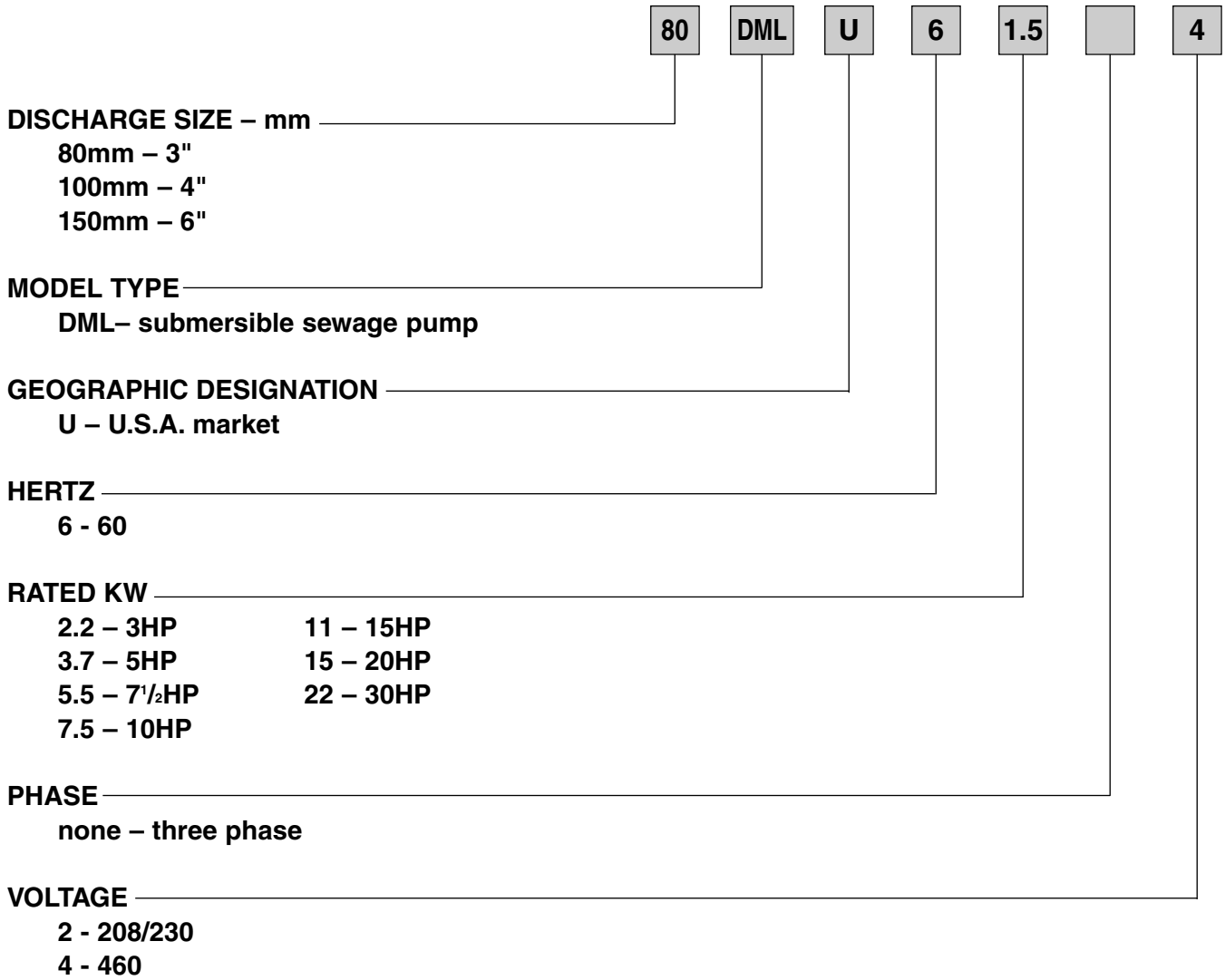

EBARA Submersible Wastewater Pumps**DMLU****Specifications****Model DMLU**
Specifications

	Standard	Optional
Size	3, 4, 6 inch	
Range of HP	3 to 30HP	
Range of Performance	Capacity: 55 to 1345 GPM Head: 12 to 136 feet	
Limitation Maximum Water Temperature	104°F (40°C)	
Synchronous Speed	1800 RPM	
Materials Casing Impeller Shaft Motor Frame Fastener	Cast Iron Cast Iron 403 Stainless Steel Cast Iron 304 Stainless Steel	
Mechanical Seal Material – Upper Side Material – Lower Side Impeller Type Bearing Motor Three Phase Service Factor Motor Protection Accessories	Double Mechanical Seal Carbon/Ceramic Silicon Carbide/Silicon Carbide Non-clog single channel Pre-lubricated Ball Bearing Air-filled, dry submersible, Class F Insulation 208/230 or 460V 1.15 3HP: Built-in Auto cut - overload, out-of-phase, single phasing protection 5 to 30HP: Built-in thermal detector Submersible cable 33 ft.	66 ft. QDC System



Selection Chart

Model DMLU
Selection chart

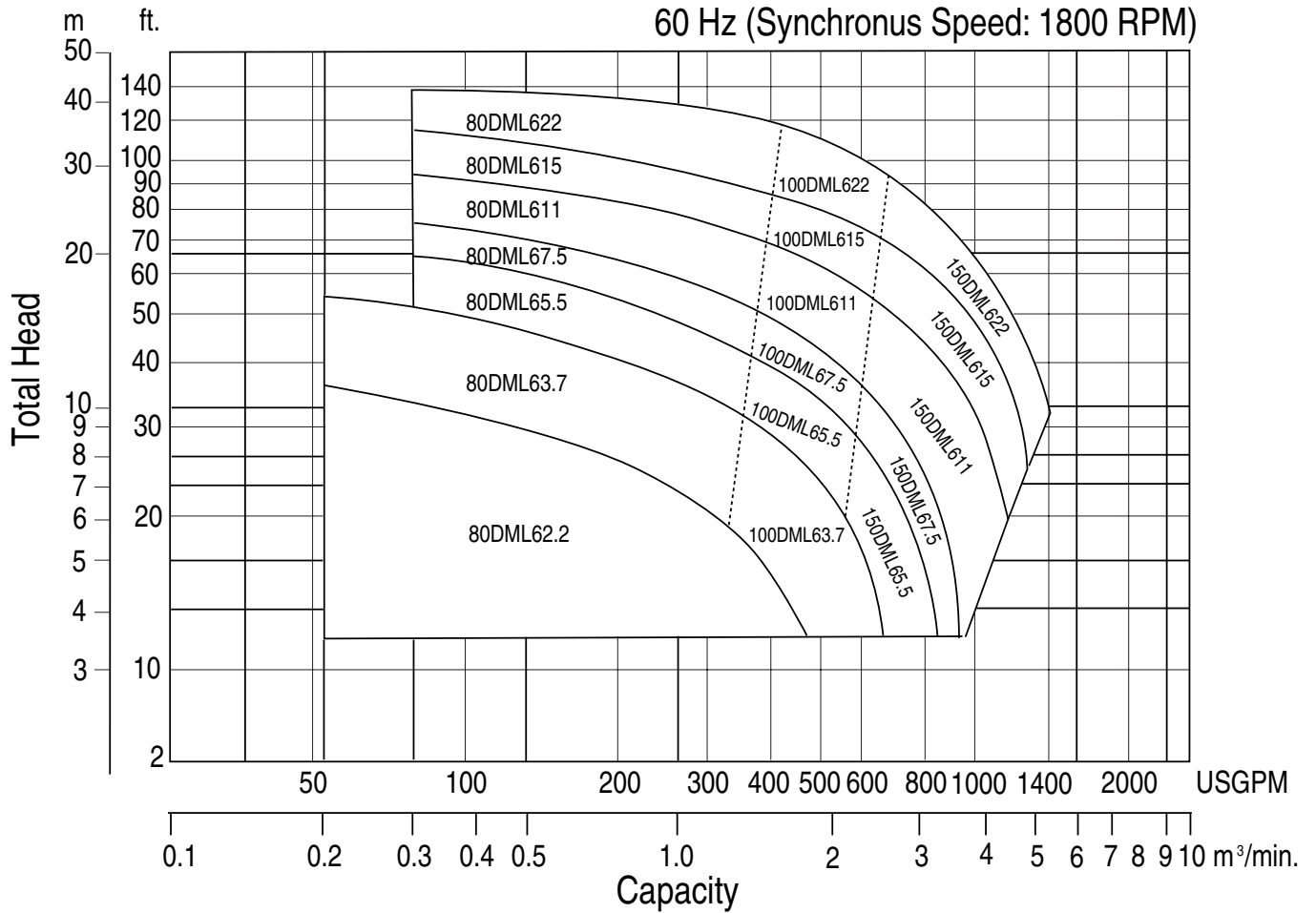

Performance Curves

80, 100, 150DML65.5 (7.5HP) Synchronous Speed: 1800 RPM 3, 4, 6 inch Discharge

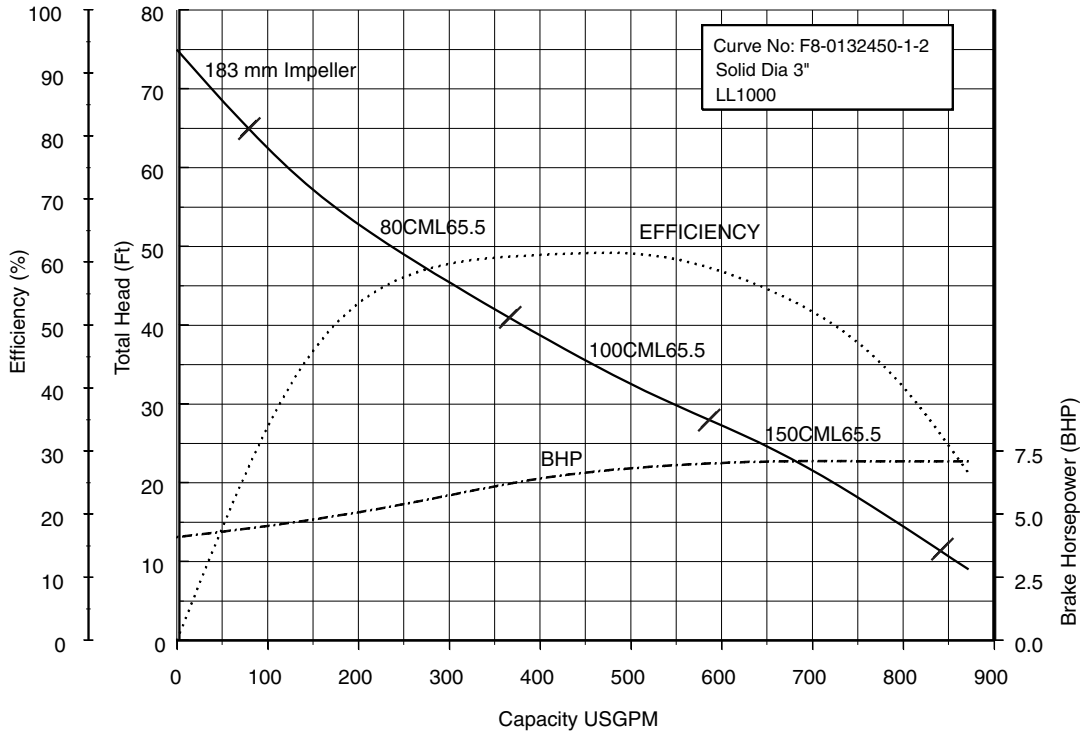

80, 100, 150DML67.5 (10HP) Synchronous Speed: 1800 RPM 3, 4, 6 inch Discharge

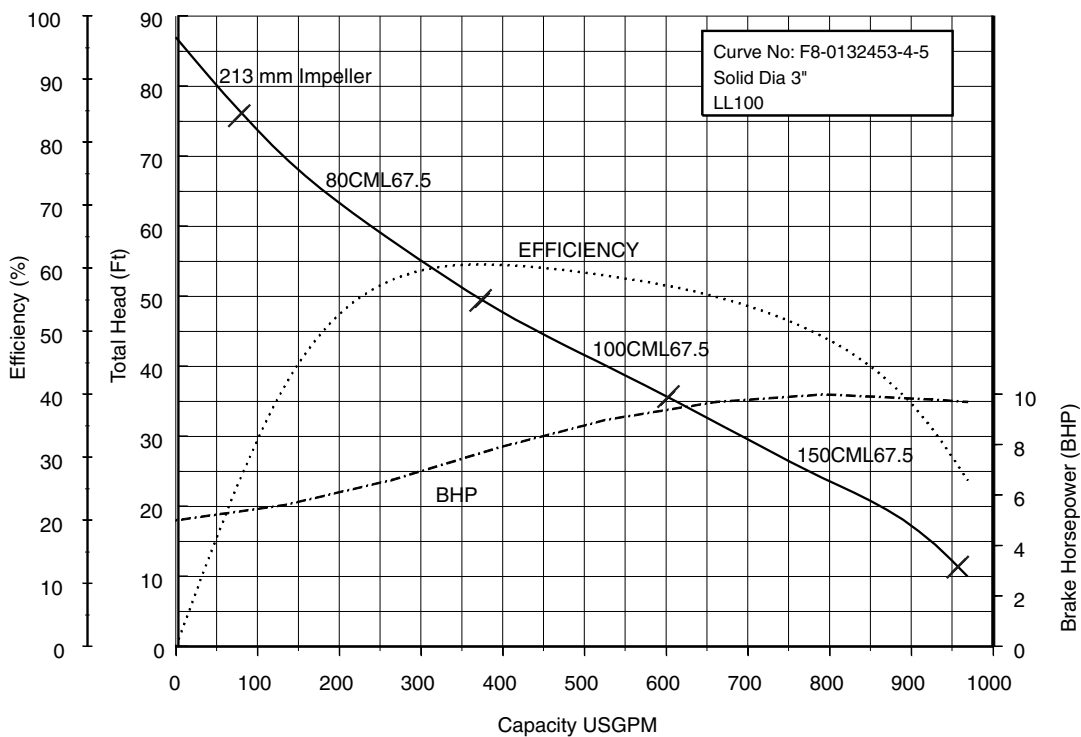

Performance Curves

80, 100, 150DML611 (15HP) Synchronous Speed: 1800 RPM 3, 4, 6 inch Discharge

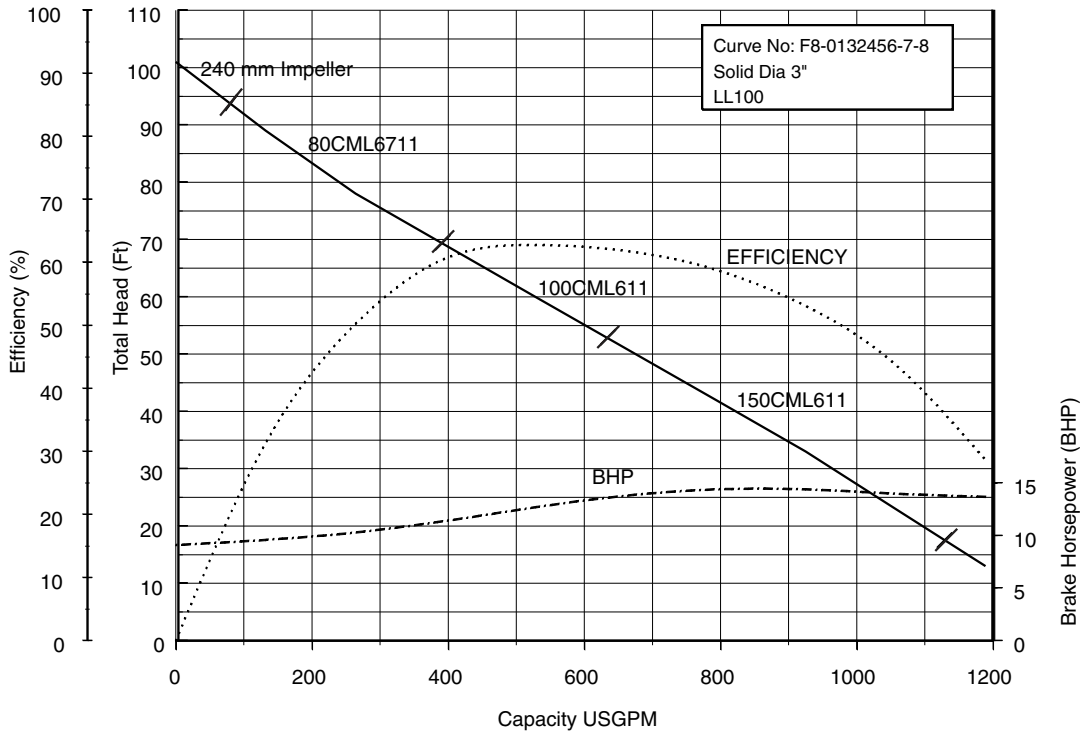

80, 100, 150DML615 (20HP) Synchronous Speed: 1800 RPM 3, 4, 6 inch Discharge

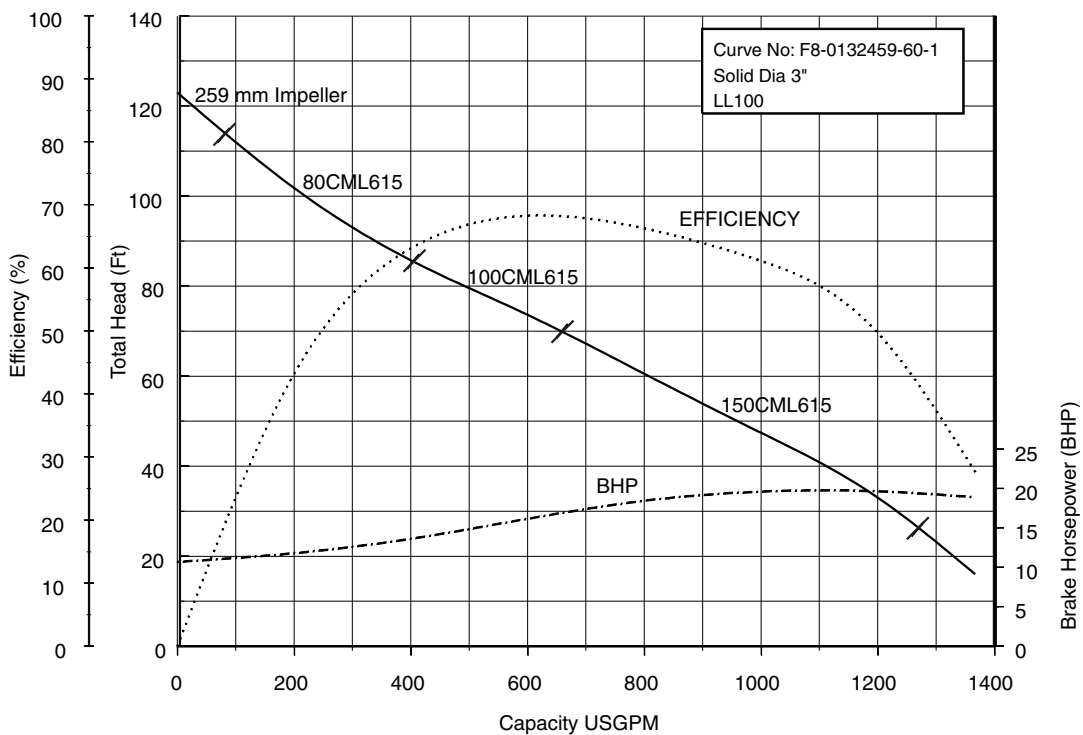

Performance Curves

80, 100, 150DML622 (30HP) Synchronous Speed: 1800 RPM 3, 4, 6 inch Discharge

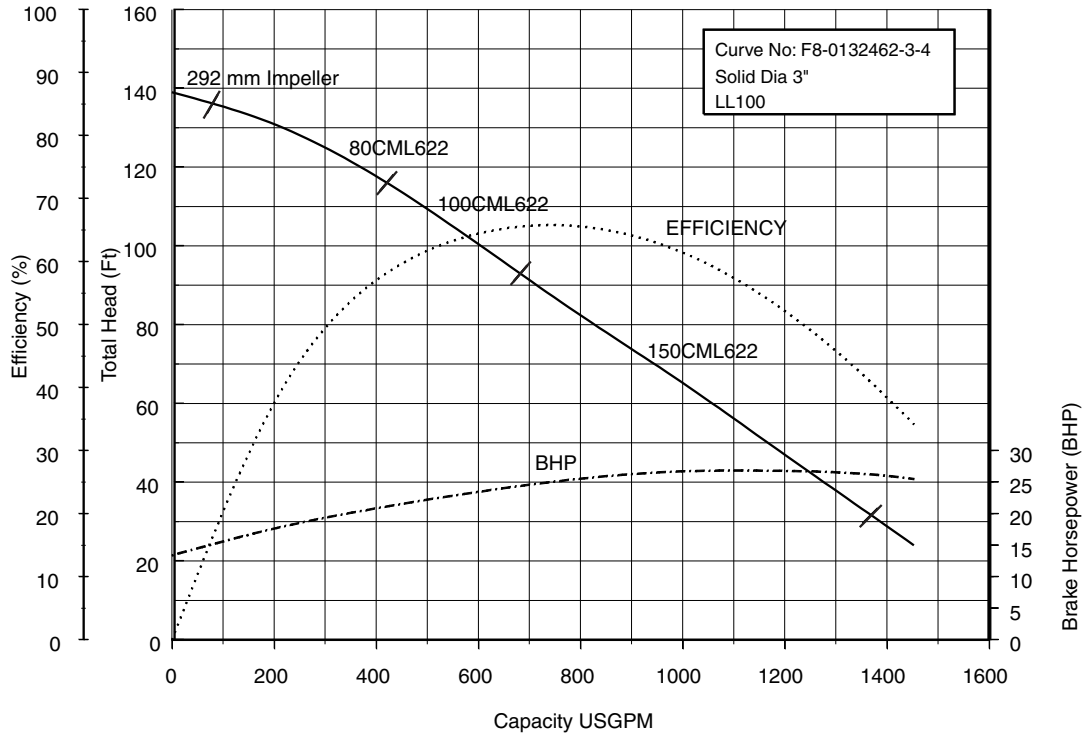

Dimensions

Model DMLU

80DMLU, 3 to 30HP
 100DMLU, 5 to 30 HP
 150DMLU, 7.5 to 30HP

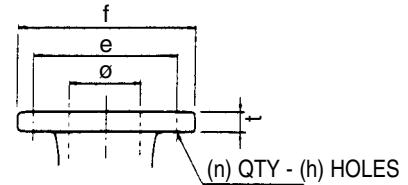
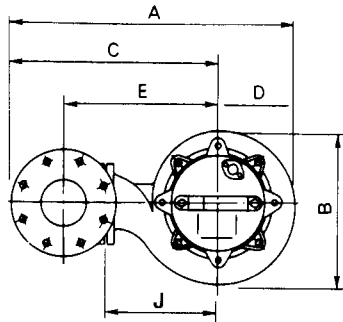
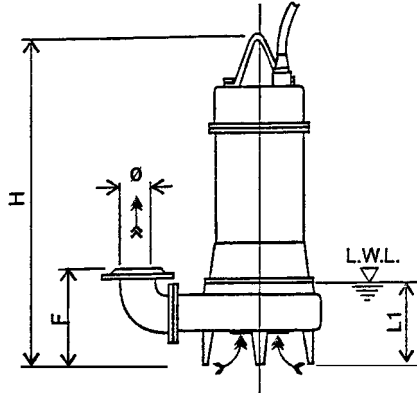

Flange (ANSI 125 PSI F.F)

inch					
ø	e	f	t	n	h
3	6	7 1/2	3/4	4	3/4
4	7 1/2	9	15/16	8	3/4
6	9 1/2	11	1	8	3/4

mm					
ø	e	f	t	n	h
80	150	185	19	4	19
100	175	210	20	8	19
150	240	280	22	8	19

Dimensions: inch

PHASE	SIZE ø	MODEL	OUTPUT		PUMP & MOTOR									WEIGHT Lb
			kW	HP	A	B	C	D	E	F	H	J	L1	
THREE	3	80DMLU62.2	2.2	3	21	12 ⁵ / ₈	14 ⁷ / ₈	6 ³ / ₁₆	11 ¹ / ₄	11 ³ / ₄	26 ⁵ / ₁₆	8 ¹ / ₄	11	176
		80DMLU63.7	3.7	5	21	12 ⁵ / ₈	14 ⁷ / ₈	6 ³ / ₁₆	11 ¹ / ₄	11 ³ / ₄	28 ⁵ / ₈	8 ¹ / ₄	11	192
		80DMLU65.5	5.5	7.5	25 ³ / ₁₆	15	17 ¹³ / ₁₆	7 ³ / ₈	14 ³ / ₁₆	13 ¹ / ₈	32 ⁷ / ₁₆	10 ¹ / ₁₆	12 ³ / ₁₆	260
		80DMLU67.5	7.5	10	25 ³ / ₁₆	15	17 ¹³ / ₁₆	7 ³ / ₈	14 ³ / ₁₆	13 ¹ / ₈	32 ⁷ / ₁₆	10 ¹ / ₁₆	12 ³ / ₁₆	271
		80DMLU611	11	15	28 ⁷ / ₈	17 ¹⁵ / ₁₆	20 ³ / ₁₆	8 ¹ / ₁₆	16 ⁹ / ₁₆	13 ³ / ₄	36 ¹⁵ / ₁₆	12 ³ / ₈	12 ¹⁵ / ₁₆	346
		80DMLU615	15	20	28 ⁷ / ₈	17 ¹⁵ / ₁₆	20 ³ / ₁₆	8 ¹ / ₁₆	16 ⁹ / ₁₆	13 ³ / ₄	36 ¹⁵ / ₁₆	12 ³ / ₈	12 ¹⁵ / ₁₆	359
	80DMLU622	22	30	30 ⁹ / ₁₆	19 ⁹ / ₁₆	21	9 ⁵ / ₈	17 ⁵ / ₁₆	14 ³ / ₁₆	40 ³ / ₁₆	13 ³ / ₁₆	13 ¹ / ₁₆	492	
	4	100DMLU63.7	3.7	5	22 ¹¹ / ₁₆	12 ⁵ / ₈	16 ⁹ / ₁₆	6 ³ / ₁₆	12 ³ / ₈	12 ⁵ / ₁₆	28 ⁵ / ₈	8 ¹ / ₄	11	196
		100DMLU65.5	5.5	7.5	25 ¹¹ / ₁₆	15	18 ⁵ / ₁₆	7 ³ / ₈	14 ³ / ₁₆	13 ¹ / ₈	32 ⁷ / ₁₆	10 ¹ / ₁₆	12 ³ / ₁₆	267
		100DMLU67.5	7.5	10	25 ¹¹ / ₁₆	15	18 ⁵ / ₁₆	7 ³ / ₈	14 ³ / ₁₆	13 ¹ / ₈	32 ⁷ / ₁₆	10 ¹ / ₁₆	12 ³ / ₁₆	276
		100DMLU611	11	15	29 ³ / ₈	17 ¹⁵ / ₁₆	20 ¹¹ / ₁₆	8 ¹ / ₁₆	16 ⁹ / ₁₆	13 ³ / ₄	36 ¹⁵ / ₁₆	12 ³ / ₈	12 ¹⁵ / ₁₆	353
		100DMLU615	15	20	29 ³ / ₈	17 ¹⁵ / ₁₆	20 ¹¹ / ₁₆	8 ¹ / ₁₆	16 ⁹ / ₁₆	13 ³ / ₄	36 ¹⁵ / ₁₆	12 ³ / ₈	12 ¹⁵ / ₁₆	366
		100DMLU622	22	30	31 ¹ / ₈	19 ⁹ / ₁₆	21 ⁷ / ₁₆	9 ⁵ / ₈	17 ⁵ / ₁₆	14 ³ / ₁₆	40 ³ / ₁₆	13 ³ / ₁₆	13 ¹ / ₁₆	498
	6	150DMLU65.5	5.5	7.5	28 ¹ / ₁₆	15	20 ¹¹ / ₁₆	7 ³ / ₈	15 ³ / ₁₆	14 ¹ / ₂	32 ⁷ / ₁₆	10 ¹ / ₁₆	12 ³ / ₁₆	280
		150DMLU67.5	7.5	10	28 ¹ / ₁₆	15	20 ¹¹ / ₁₆	7 ³ / ₈	15 ³ / ₁₆	14 ¹ / ₂	32 ⁷ / ₁₆	10 ¹ / ₁₆	12 ³ / ₁₆	291
150DMLU611		11	15	31 ³ / ₄	17 ¹⁵ / ₁₆	23 ¹ / ₁₆	8 ¹ / ₁₆	17 ¹ / ₂	15 ³ / ₁₆	36 ¹⁵ / ₁₆	12 ³ / ₈	12 ¹⁵ / ₁₆	366	
150DMLU615		15	20	31 ³ / ₄	17 ¹⁵ / ₁₆	23 ¹ / ₁₆	8 ¹ / ₁₆	17 ¹ / ₂	15 ³ / ₁₆	36 ¹⁵ / ₁₆	12 ³ / ₈	12 ¹⁵ / ₁₆	379	
150DMLU622		22	30	33 ⁷ / ₁₆	19 ⁹ / ₁₆	23 ¹³ / ₁₆	9 ⁵ / ₈	18 ⁵ / ₁₆	15 ¹¹ / ₁₆	40 ³ / ₁₆	13 ³ / ₁₆	13 ¹ / ₁₆	511	

Dimensions: mm

PHASE	SIZE ø	MODEL	OUTPUT		PUMP & MOTOR									WEIGHT kg
			kW	HP	A	B	C	D	E	F	H	J	L1	
THREE	80	80DMLU62.2	2.2	3	534	320	378	157	285	298	668	210	279	80
		80DMLU63.7	3.7	5	534	320	378	157	285	298	727	210	279	87
		80DMLU65.5	5.5	7.5	640	381	453	188	360	334	824	255	310	118
		80DMLU67.5	7.5	10	640	381	453	188	360	334	824	255	310	123
		80DMLU611	11	15	734	455	513	221	420	350	938	315	329	157
		80DMLU615	15	20	734	455	513	221	420	350	938	315	329	163
	80DMLU622	22	30	777	497	533	245	440	363	1021	335	332	223	
	100	100DMLU63.7	3.7	5	577	320	420	157	315	313	727	210	279	89
		100DMLU65.5	5.5	7.5	653	381	465	188	360	334	824	255	310	121
		100DMLU67.5	7.5	10	653	381	465	188	360	334	824	255	310	125
		100DMLU611	11	15	746	455	525	221	420	350	938	315	329	160
		100DMLU615	15	20	746	455	525	221	420	350	938	315	329	166
		100DMLU622	22	30	790	497	545	245	440	363	1021	335	332	226
	150	150DMLU65.5	5.5	7.5	713	381	525	188	385	369	824	255	310	127
		150DMLU67.5	7.5	10	713	381	525	188	385	369	824	255	310	132
		150DMLU611	11	115	806	455	585	221	445	385	938	315	329	166
		150DMLU615	15	20	806	455	585	221	445	385	938	315	329	172
		150DMLU622	22	30	850	497	605	245	465	398	1021	335	332	232

Dimensions

Model DMLU with Quick Discharge Connector

80DMLU62.2

80DMLU63.7

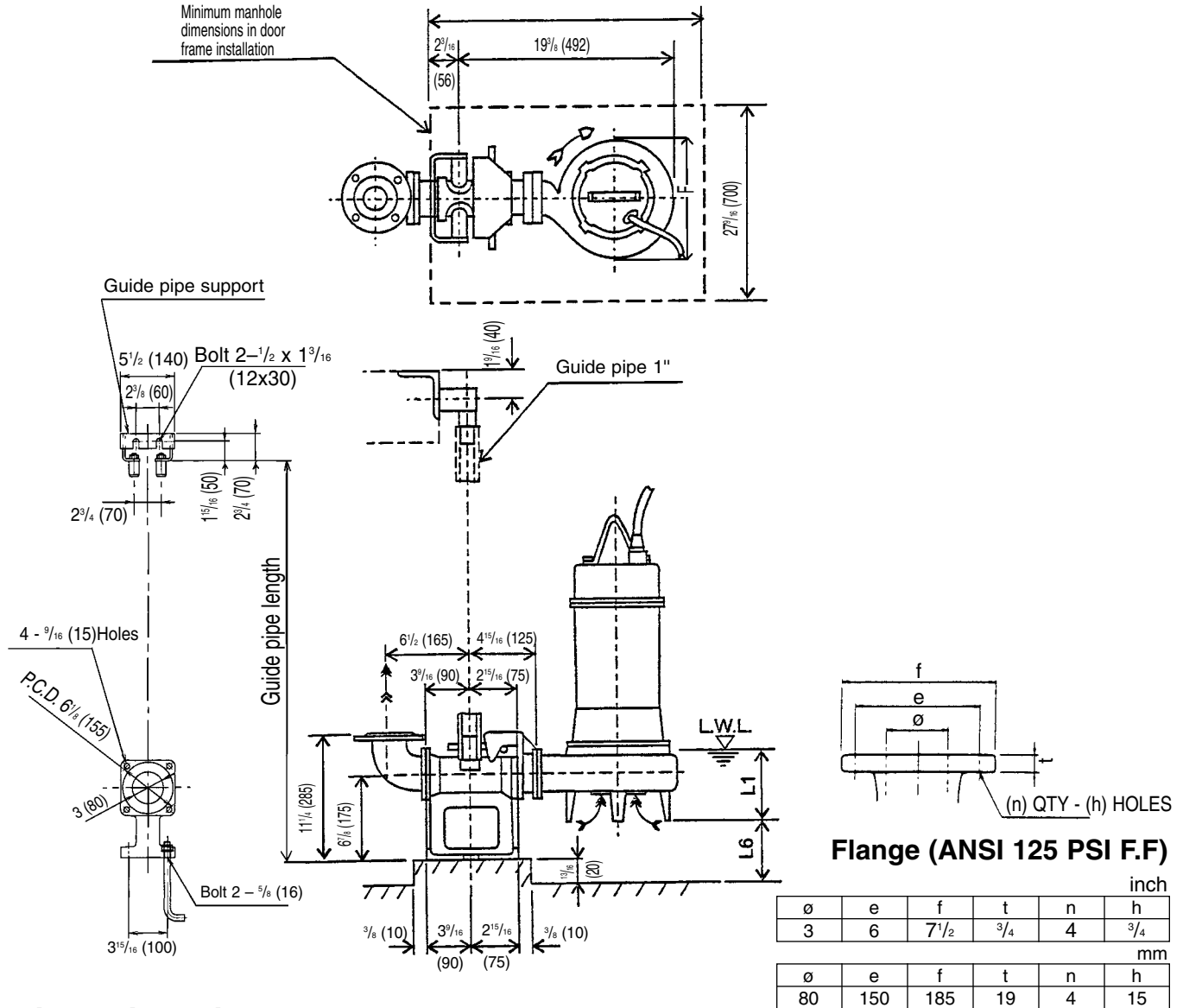

Dimensions: inch

PHASE	SIZE ø	MODEL	OUTPUT		Q.D.C. MODEL	PUMP & MOTOR			WEIGHT Lb	
			kW	HP		F	L1	L6	PUMP	Q.D.C.
THREE	3	80DML62.2	2.2	3	LM80	12 ⁵ / ₈	11	1/4	176	37
		80DML63.7	3.7	5	LM80	12 ⁵ / ₈	11	1/4	192	37
	4	100DMLU63.7	3.7	5	LM80	12 ⁵ / ₈	11	1/4	196	37

Dimensions: mm

PHASE	SIZE ø	MODEL	OUTPUT		Q.D.C. MODEL	PUMP & MOTOR			WEIGHT Lb	
			kW	HP		F	L1	L6	PUMP	Q.D.C.
THREE	80	80DML62.2	2.2	3	LM80	320	279	7	80	17
		80DML63.7	3.7	5	LM80	320	279	7	87	17
	100	100DMLU63.7	3.7	5	LM80	320	279	7	89	17

Dimensions

Model DMLU with Quick Discharge Connector

80DMLU
100DMLU

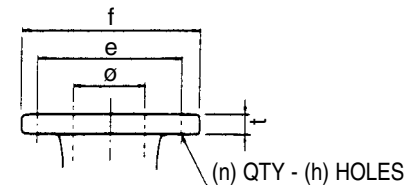
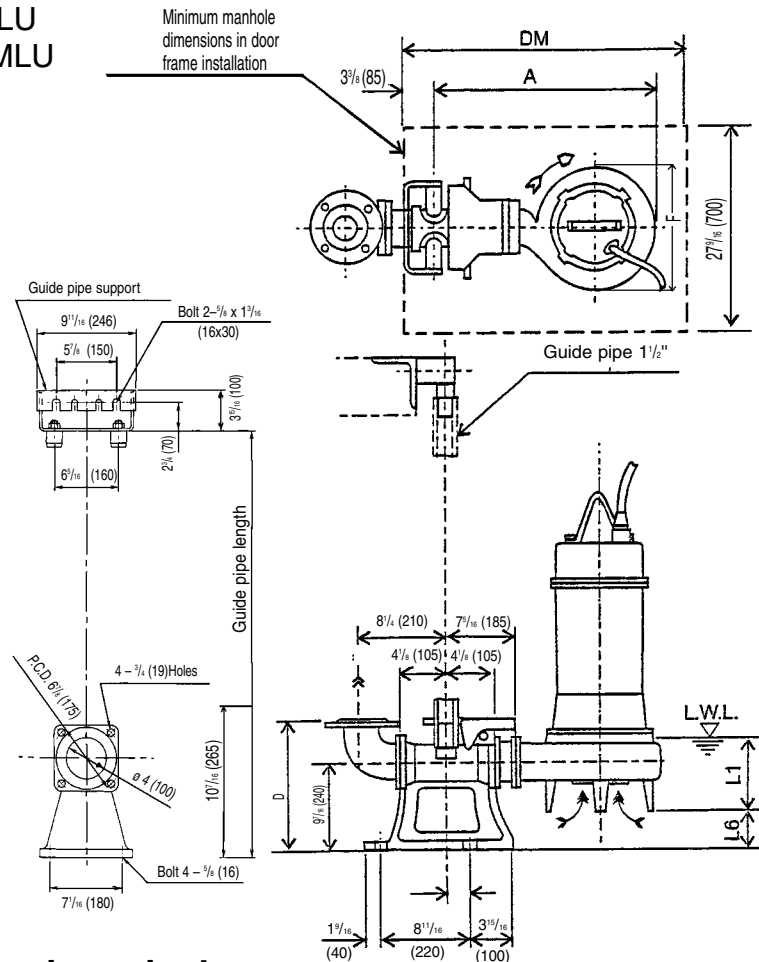

Flange (ANSI 125 PSI F.F)

inch					
ø	e	f	t	n	h
3	6	7 1/2	3/4	4	3/4
4	7 1/2	9	15/16	8	3/4

mm					
ø	e	f	t	n	h
80	150	185	19	4	19
100	175	210	20	8	19

Dimensions: inch

PHASE	SIZE ø	MODEL	OUTPUT		Q.D.C. MODEL	PUMP & MOTOR						WEIGHT Lb	
			kW	HP		A	D	F	L1	L6	DM	PUMP	Q.D.C.
THREE	3	80DMLU65.5	5.5	7.5	LL100	24 3/4	14 3/8	15	12 3/16	1 1/4	31 1/2	260	101
		80DMLU67.5	7.5	10	LL100	24 3/4	14 3/8	15	12 3/16	1 1/4	31 1/2	271	101
		80DMLU611	11	15	LL100	28 3/8	14 3/8	17 15/16	12 15/16	9/16	39 3/8	346	101
		80DMLU615	15	20	LL100	28 3/8	14 3/8	17 15/16	12 15/16	9/16	39 3/8	359	101
		80DMLU622	22	30	LL100	30 1/8	14 3/8	19 9/16	13 1/16	1/2	39 3/8	492	101
	4	100DMLU65.5	5.5	7.5	LL100	24 3/4	14 3/8	15	12 3/16	1 1/4	31 1/2	267	101
		100DMLU67.5	7.5	10	LL100	24 3/4	14 3/8	15	12 3/16	1 1/4	31 1/2	276	101
		100DMLU611	11	15	LL100	28 3/8	14 3/8	17 15/16	12 15/16	9/16	39 3/8	353	101
		100DMLU615	15	20	LL100	28 3/8	14 3/8	17 15/16	12 15/16	9/16	39 3/8	366	101
		100DMLU622	22	30	LL100	30 1/8	14 3/8	19 9/16	13 1/16	1/2	39 3/8	498	101

Dimensions: mm

PHASE	SIZE ø	MODEL	OUTPUT		Q.D.C. MODEL	PUMP & MOTOR						WEIGHT Lb	
			kW	HP		A	D	F	L1	L6	DM	PUMP	Q.D.C.
THREE	80	80DMLU65.5	5.5	7.5	LL100	628	365	381	310	31	800	118	46
		80DMLU67.5	7.5	10	LL100	628	365	381	310	31	800	123	46
		80DMLU611	11	15	LL100	721	365	455	329	15	1000	157	46
		80DMLU615	15	20	LL100	721	365	455	329	15	1000	163	46
		80DMLU622	22	30	LL100	765	365	497	332	12	1000	223	46
	100	100DMLU65.5	5.5	7.5	LL100	628	365	381	310	31	800	121	46
		100DMLU67.5	7.5	10	LL100	628	365	381	310	31	800	125	46
		100DMLU611	11	15	LL100	721	365	455	329	15	1000	160	46
		100DMLU615	15	20	LL100	721	365	455	329	15	1000	166	46
		100DMLU622	22	30	LL100	765	365	497	332	12	1000	226	46

Dimensions

Model DMLU with Quick Discharge Connector
150DMLU

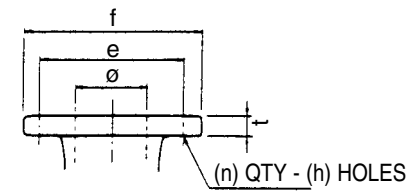
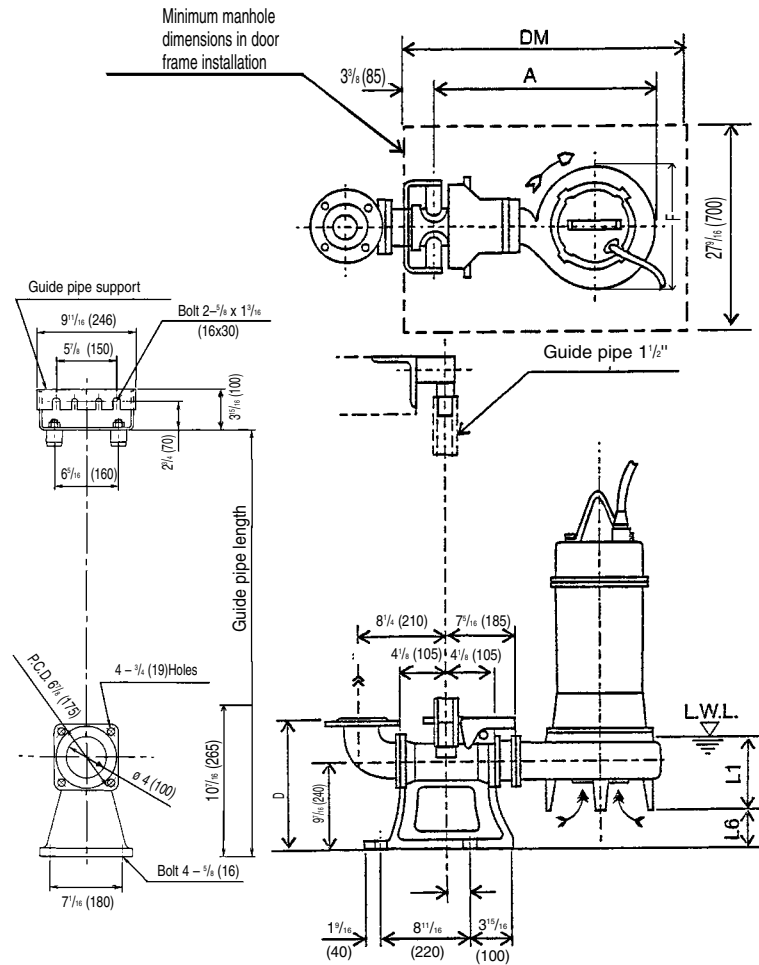

Flange (ANSI 125 PSI F.F)

ø	e	f	t	n	h
6	9 1/2	11	1	8	3/4
mm					
ø	e	f	t	n	h
150	240	280	212	8	19

Dimensions: inch

PHASE	SIZE ø	MODEL	OUTPUT		Q.D.C. MODEL	PUMP & MOTOR					WEIGHT Lb		
			kW	HP		A	D	F	L1	L6	DM	PUMP	Q.D.C.
THREE	6	150DMLU65.5	5.5	7.5	LL100	24 3/4	15 3/4	15	12 3/16	1 1/4	31 1/2	280	101
		150DMLU67.5	7.5	10	LL100	24 3/4	15 3/4	15	12 3/16	1 1/4	31 1/2	291	101
		150DMLU611	11	115	LL100	28 3/8	15 3/4	17 15/16	12 15/16	9/16	39 3/8	366	101
		150DMLU615	15	20	LL100	28 3/8	15 3/4	17 15/16	12 15/16	9/16	39 3/8	379	101
		150DMLU622	22	30	LL100	30 1/8	15 3/4	19 9/16	13 1/16	1/2	39 3/8	511	101

Dimensions: mm

PHASE	SIZE ø	MODEL	OUTPUT		Q.D.C. MODEL	PUMP & MOTOR					WEIGHT Lb		
			kW	HP		A	D	F	L1	L6	DM	PUMP	Q.D.C.
THREE	150	150DMLU65.5	5.5	7.5	LL100	628	400	381	310	31	800	127	46
		150DMLU67.5	7.5	10	LL100	628	400	381	310	31	800	132	46
		150DMLU611	11	115	LL100	721	400	455	329	15	1000	166	46
		150DMLU615	15	20	LL100	721	400	455	329	15	1000	172	46
		150DMLU622	22	30	LL100	765	400	497	332	12	1000	232	46

Sectional View

80DML62.2

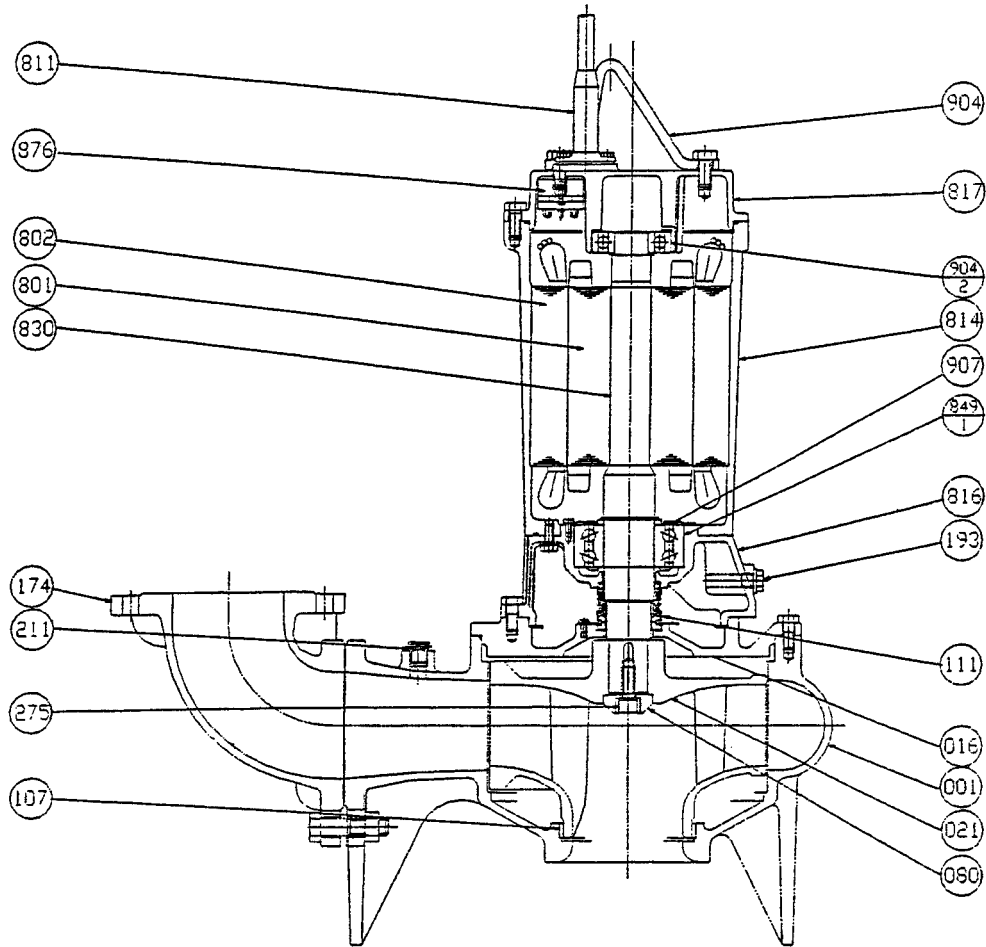

PART NO.	PART NAME	MATERIAL	NO. FOR 1 UNIT
001	CASING	CAST IRON	1
016	MECHANICAL SEAL COVER	CAST IRON	1
021	IMPELLER	CAST IRON	1
080	BUSHING	STAINLESS STEEL	1
107	WEAR RING	BRONZE	1
111	MECHANICAL SEAL	—	1
174	DISCHARGE PIPE	CAST IRON	1 SET
193	OIL PLUG	RUBBER (NBR)	1 SET
211	AIRVENT VALVE	BRASS	1
275	IMPELLER BOLT	STAINLESS STEEL	1
801	ROTOR	—	1
802	STATOR	—	1

PART NO.	PART NAME	MATERIAL	NO. FOR 1 UNIT
811	SUBMERSIBLE CABLE	—	2
814	MOTOR FRAME	CAST IRON	1
816	POWER SIDE BRACKET	CAST IRON	1
817	OPPOSITE SIDE BRACKET	CAST IRON	1
830	SHAFT	STAINLESS STEEL	1
849-1	BALL BEARING	—	1
849-2	BALL BEARING	—	1
876	AUTO CUT	—	3
904	LIFTING HANGER	STEEL	1
907	BEARING COVER	STEEL	1

Sectional View

5 to 10 HP
 80DML
 100DML
 150DML

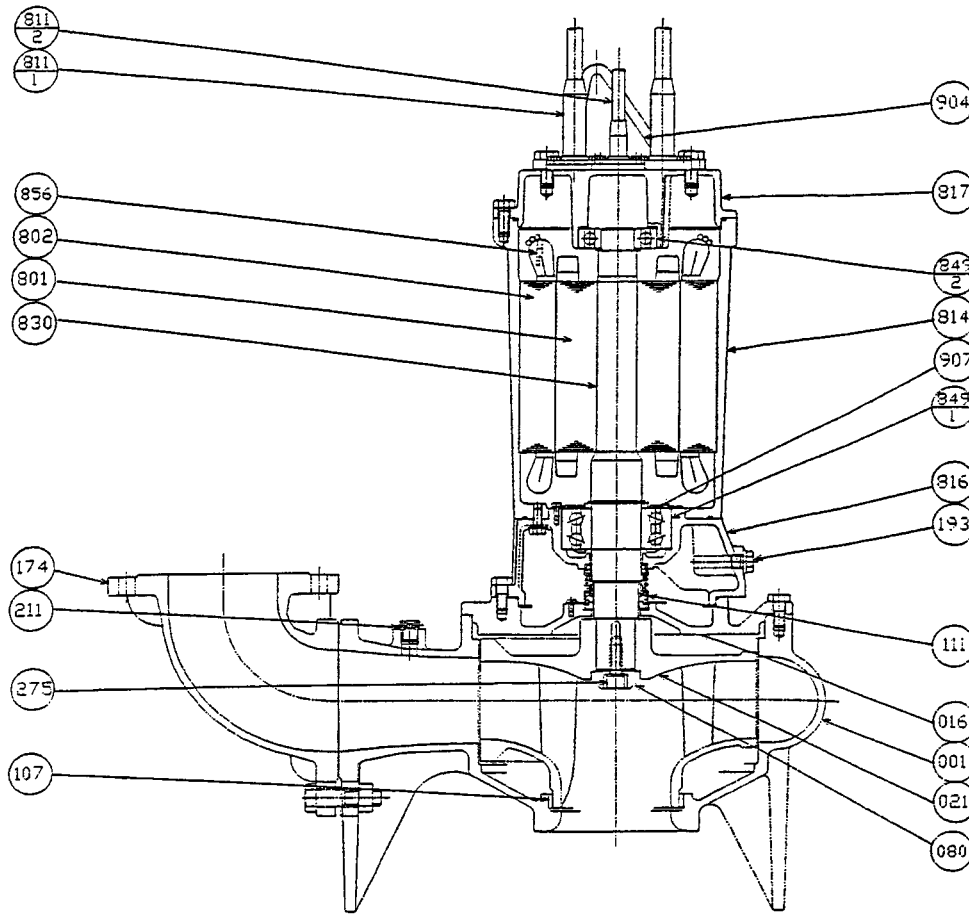

PART NO.	PART NAME	MATERIAL	NO. FOR 1 UNIT
001	CASING	CAST IRON	1
016	MECHANICAL SEAL COVER	CAST IRON	1
021	IMPELLER	CAST IRON	1
080	BUSHING	STEEL	1
107	WEARING RING	BRONZE	1
111	MECHANICAL SEAL	—	1
174	DISCHARGE PIPE	CAST IRON	1
193	OIL PLUG	RUBBER (NBR)	1 SET
211	AIRVENT VALVE	BRASS	1
275	IMPELLER BOLT	STAINLESS STEEL	1
801	ROTOR	—	1
802	STATOR	—	1

PART NO.	PART NAME	MATERIAL	NO. FOR 1 UNIT
811-1	SUBMERSIBLE CABLE (POWER)	—	2
811-2	SUBMERSIBLE CABLE (SIGNAL)	—	1
814	MOTOR FRAME	CAST IRON	1
816	POWER SIDE BRACKET	CAST IRON	1
817	OPPOSITE SIDE BRACKET	CAST IRON	1
830	SHAFT	STAINLESS STEEL	1
849-1	BALL BEARING	—	1
849-2	BALL BEARING	—	1
856	THERMAL PROTECTOR	—	3
904	LIFTING HANGER	STEEL	1
907	BEARING COVER	STEEL	1

Sectional View

15 to 30HP
 80DML
 100DML
 150DML

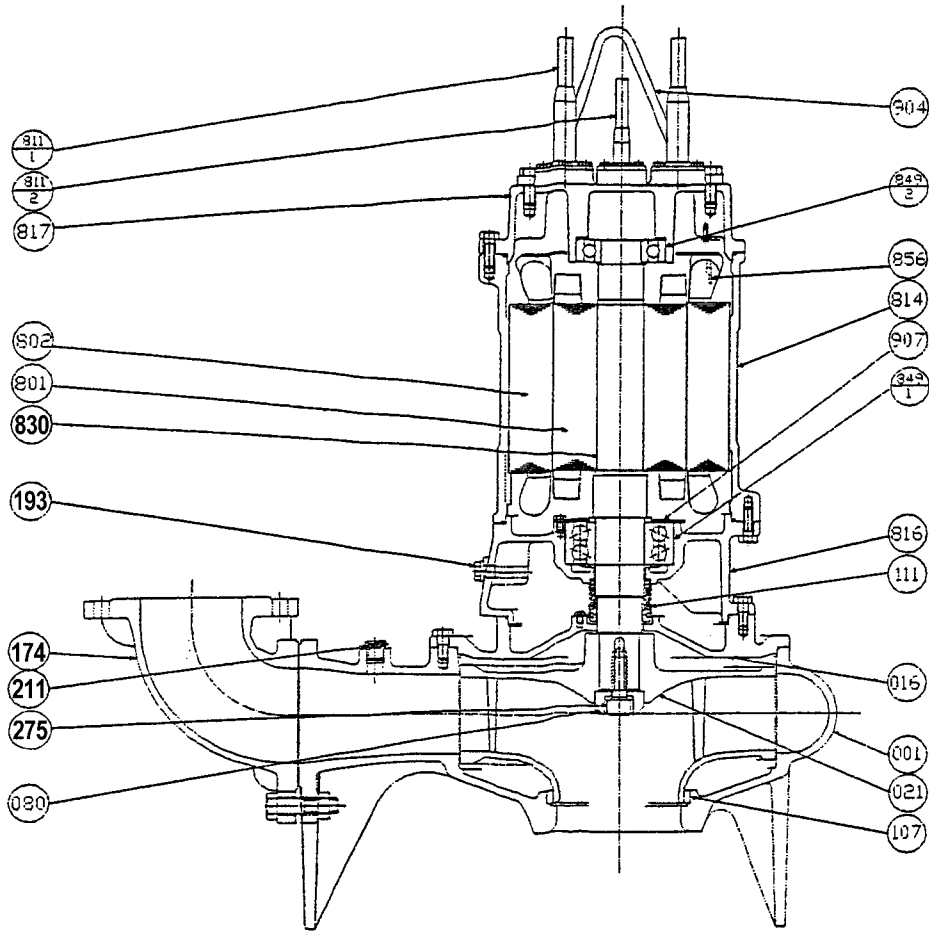

PART NO.	PART NAME	MATERIAL	NO. FOR 1 UNIT
001	CASING	CAST IRON	1
016	MECHANICAL SEAL COVER	CAST IRON	1
021	IMPELLER	CAST IRON	1
080	BUSHING	STEEL	1
107	WEARING RING	BRONZE	1
111	MECHANICAL SEAL	—	1
174	DISCHARGE PIPE	CAST IRON	1
193	OIL PLUG	RUBBER (NBR)	1 SET
211	AIRVENT VALVE	BRASS	1
275	IMPELLER BOLT	STAINLESS STEEL	1
801	ROTOR	—	1
802	STATOR	—	1

PART NO.	PART NAME	MATERIAL	NO. FOR 1 UNIT
811-1	SUBMERSIBLE CABLE (POWER)	—	2
811-2	SUBMERSIBLE CABLE (SIGNAL)	—	1
814	MOTOR FRAME	CAST IRON	1
816	POWER SIDE BRACKET	CAST IRON	1
817	OPPOSITE SIDE BRACKET	CAST IRON	1
830	SHAFT	STAINLESS STEEL	1
849-1	BALL BEARING	—	1
849-2	BALL BEARING	—	1
856	THERMAL PROTECTORT	—	3
904	LIFTING HANGER	STEEL	1
907	BEARING COVER	STEEL	1