

CALL 1-800-577-8111 FOR SALES AND SUPPORT



Instruction and Operation Manual
Model DMLU



CALL 1-800-577-8111 FOR SALES AND SUPPORT

DMLU

Instruction, Operation, and Maintenance

Contents

Section	Page
Safety Information	2
Delivery Checks	3
Specifications	3
Installation	4
Operation	5
Maintenance	6
Troubleshooting	7
Disassembly and Reassembly	8
Parts	9
Warranty	12

Safety Information and Introduction

Warnings in this manual provide information for safe use of your EBARA pump, and instructions for preventing injury to those operating it. Please pay close attention to the instructions listed below. If there are any questions regarding these instructions, please direct them to EBARA INTERNATIONAL CORPORATION.

1. Before lifting the pump, confirm the total weight of the unit listed in the catalog or outline drawing. Use the appropriate hoist or crane assembly, and make sure that the load is balanced to prevent shifting during loading and off-loading.
2. Be sure to keep the pump from lying on the power and control cables, and do not use the power and control cables to lift the pump. This can result in damage to the cables and can cause electrical shorts that can possibly lead to fires.
3. A qualified electrician should perform all wiring and all national and local electrical codes must be observed.
4. Make sure that all equipment is properly grounded. Failure to do so can result in electric shock.
5. Disassembly and repair of the pump should only be performed by factory trained service centers. Errors made by unqualified personnel can result in improper assembly and operation, therefore resulting in possible injury.
6. Always make sure that power switch is in OFF position and that power cable is disconnected before inspecting or repairing the pump.
7. If pump is to be out of service for a long period of time, turn power off. If power is left on without operating pump it can cause insulation breakdown, resulting in a possible motor short or electric shock.
8. Do not insert hands into the pump during operation.
9. Do not operate the pump unsubmerged, as overheating can occur, causing insulation breakdown and possible electric shock.
10. If the insulation resistance is below $1M\Omega$, turn power off to unit as soon as possible, as electric shock can occur.



DMLU

Delivery Checks

When your pump is delivered, check the following items immediately.

1. Pump and accessories
 - a.) Confirm that no damage has occurred during transportation.
 - b.) Confirm that all items have been delivered.

2. Nameplate
 - a.) The basic specifications of the pump are listed on the nameplate. Read the pump nameplate to confirm that the pump you received matches the specifications that you ordered.

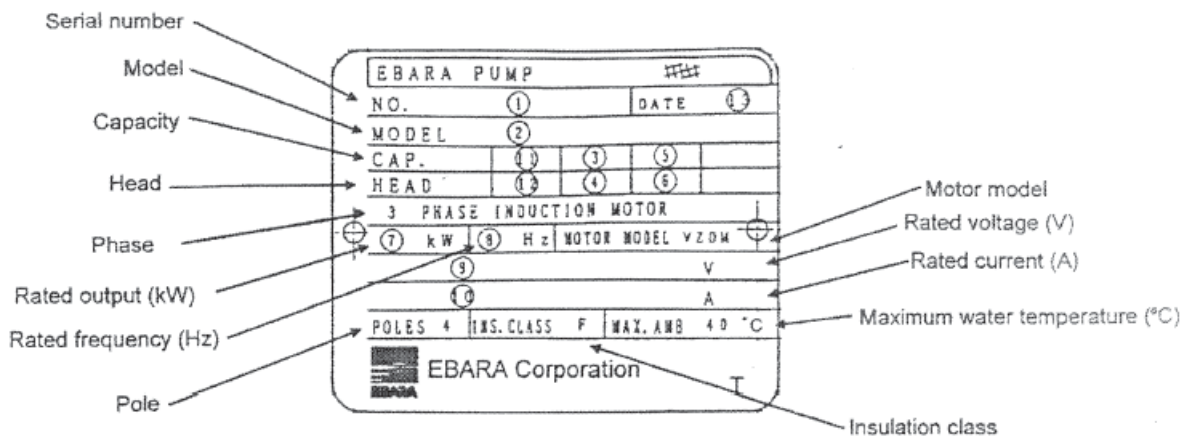

Fig. 1 – Pump Nameplate

Specifications

	Item	Specifications
Liquid handled	Type	Waste water
	Temperature	0 - 40° C
Solids Capacity	Discharge size (in.)	3, 4, 6
	Solid size (in.)	3
Materials	Impeller	Cast iron
	Phase	Three Phase
	Hz	60 Hz
Motor	Voltage	230 or 460 VAC
	Starting Method	2.2kW : Direct start 3.7 ~ 22kW : Star-Delta start
	Protector	2.2kW : Auto-cut
		3.7 ~ 22kW : Thermal Protector
Mechanical Seal Lubricants		Turbine oil ISO VG32
Maximum water depth		26 ft.
Installation		with Quick Discharge Connector or Floor mounted

DMLU

Installation

1. Before installation:
 - a.) Use a megger to measure the insulation resistance between the ground wire and each phase of the motor. Keep the ground wire off the ground during measurement. The value of each reading should be more than 20 meg-ohms.
2. Installation:
 - a.) Using a chain or lifting cable assembly, lower the pump into the tank or wet well.
DO NOT USE THE POWER & SENSOR CABLE TO LIFT PUMP.
 - b.) Do not install the pump horizontally. Ensure that the pump is upright and on a secure base. Installation of pump with Quick Discharge Connector (QDC) shall be in accordance with manual entitled "Quick Discharge Connector."
 - c.) Install pump in a location within the tank that has the least amount of turbulence.
 - d.) Support the discharge piping to prevent vibration.
 - e.) Install proper ventilation so that air will not become stagnant.
 - f.) Do not permit the end of the discharge piping to become submerged, as it will result in backflow when the pump stops.
 - g.) Set control operating levels (i.e. floats) so that pump is not running for more than ten minutes with water level at minimum operating level as indicated in below chart. Continuous operation of pump at minimum water level will result in automatic cut-off switch in motor to be activated.

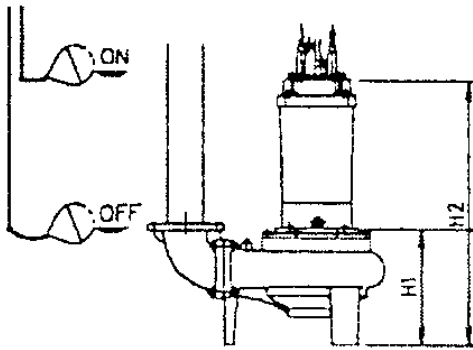

Motor Size (HP)	3	5	7.5	10	15	20	30
H2 (in)	21 ⁹ / ₁₆	24 ¹¹ / ₁₆	27 ¹³ / ₁₆	27 ¹³ / ₁₆	30 ³ / ₈	30 ³ / ₈	32 ⁵ / ₈
H1 (in)	11	11	11 ⁹ / ₁₆	11 ⁹ / ₁₆	12 ¹¹ / ₁₆	12 ¹¹ / ₁₆	12 ¹⁵ / ₁₆

Figure 2

3. Electrical Wiring:

Note: All electrical wiring should be performed by a qualified electrician, and in accordance with all national and local electrical codes. Incorrect wiring can result in serious injury.

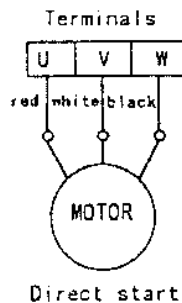

Figure 3

- a.) Wiring should be performed as indicated in Figure 3.
- b.) Do not allow the end of the cables to become immersed in water.
- c.) Make sure pump is properly grounded using the green ground wire in the power cable. Do not connect the green wire to the power supply.



DMLU**Installation** *(continued)*

d.) Motor protection:

- For 3HP motors, a built-in auto-cut is used and will be activated when motor becomes overheated due to abnormal conditions such as locked rotor or single phasing. There is no external wiring for this feature.
- For 5HP to 30HP motors, a normally closed built-in thermal protector is used. When motor winding becomes over-heated, the circuit is opened, shutting the motor down and allowing it to cool. An external sensor cable is provided for this feature and must be connected to a thermal relay in the control panel. Failure to do so will void the warranty. Specifications for the thermal protector are listed below:

Contact rating: AC 230V, 13A (Max)
 Contact type: Break contact (normally closed)

Operation

1. After completing installation, measure the insulation resistance again, using the procedure described in the "Installation" section.
2. Check to make sure there is an adequate amount of water in the wet well. Continuous operation of the pump in a dry condition will cause the motor protector to be activated.
3. Check the direction of rotation by turning on pump. If the discharge volume is low or unusual sounds are heard, it is likely that rotation has been reversed. If this happens, reverse two of the three power cable wires. (see Figure 4)

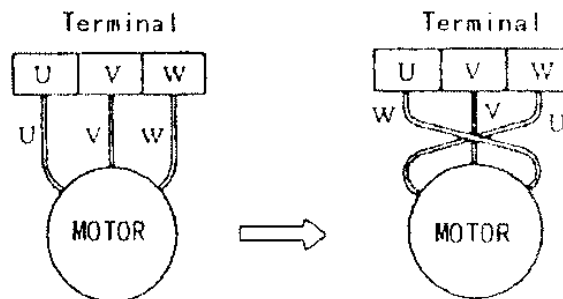
**Figure 4**

4. After confirming that the direction of rotation is correct, gradually open the discharge valve and allow the pump to run in continuous operation. Check the voltage, current and discharge pressure to make sure they are within allowable limits.
5. If voltage, current and discharge pressure are acceptable, you may continue to operate the pump on a continuous basis. Please refer to "Troubleshooting" section of the manual or contact your local EBARA distributor if one of these items is outside of allowable limits.
6. Do not allow the motor to start more than 20 times per hour.

DMLU

Maintenance

Note: Disassembly and repair of the pump should only be performed by factory trained service centers. Errors made by unqualified personnel can result in improper assembly and operation, therefore resulting in possible injury.

Warning

Always turn the power OFF before inspecting and repair the pump. Failure to do so can result in serious injury.

1. Recommended daily inspections:
 - a.) Check the motor current and its fluctuation. If there is a great deal of fluctuation, something may be clogging the pump.
 - b.) Check to make sure the pump is providing the correct amount of flow. If the discharge decreases dramatically, something may be clogging the pump.
2. Recommended monthly inspections:
 - a.) Measure the insulation resistance. The value should be more than 1 meg-ohm. If the resistance falls rapidly even with an initial reading of more than 1 meg-ohm, further inspection and possible repair may be required.
3. Recommended annual inspections:
 - a.) Check the oil in the seal chamber. If the oil has turned white it is an indication that water has mixed with the oil and the mechanical seal needs to be replaced. The service life of the mechanical seal can be prolonged by replacing the oil in the seal chamber on an annual basis. See the recommended amount of oil below in Figure 5. Replace the oil by laying the pump on its side as illustrated in Figure 6.

Motor Size (HP)	3	5	7.5	10	15	20	30
Mechanical seal (mm)	30		40		45		
Lubricating oil (oz) Turbine oil ISO VG32	38		58		102		

Figure 5

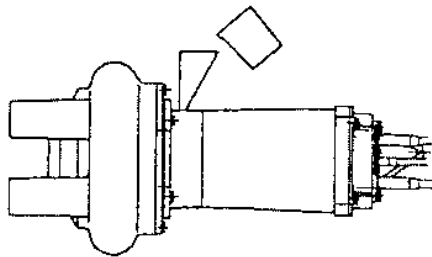

Figure 6

4. Extended storage:
 - a.) Keep pump in a dry environment, out of direct sunlight.
 - b.) Every 30 days, check the insulation resistance and rotate the impeller by hand to prevent rotating parts from seizing together.

DMLU

Troubleshooting

Trouble	Cause	Remedy
<p>Motor won't turn. Starts, but immediately stops.</p>	<ol style="list-style-type: none"> (1) Foreign matter hinders level control float from functioning properly. (2) Power failure. (3) Large voltage unbalance. (4) Significant drop in voltage (5) There is an open phase (6) Faulty circuit connection (7) Blown fuse (8) Faulty starter (9) Defective float (10) Malfunctioning circuit breaker (11) Foreign matter clogging pump (12) Motor is shorted out (13) Motor bearings are frozen 	<ol style="list-style-type: none"> (1) Remove foreign matter (2 - 3) Contact electric power company for remedy (4) Check power supply (5) Check power supply; Inspect starter and connections (6) Correct wiring (7) Replace with correct size fuse (8) Replace with correct starter (9) Repair or replace float (10) Repair location of circuit (11) Remove clog from pump (12) Repair or replace (13) Repair or replace
<p>Operates, but stops after a while. Thermal protector is activated.</p>	<ol style="list-style-type: none"> (1) Prolonged dry operation has activated motor protector and caused pump to stop (2) High liquid temperature has activated motor protector and caused pump to stop 	<ol style="list-style-type: none"> (1) Raise the off float level (2) Lower liquid temperature
<p>Does not pump. Inadequate volume.</p>	<ol style="list-style-type: none"> (1) Reverse rotation (2) Valve is closed or partially clogged. (3) Significant drop in voltage (4) Discharge head is too high (5) Large piping loss (6) Low water level during operation causes vortexing (air suction) (7) Leak in discharge piping (8) Clog in discharge piping (9) Foreign matter clogging pump (10) Worn impeller 	<ol style="list-style-type: none"> (1) Correct rotation (2) Open valve (3) Check power supply (4) Recalculate and adjust (5) Recalculate and adjust (6) Raise water level or lower pump (7) Inspect, repair (8) Remove foreign matter (9) Remove foreign matter (10) Replace impeller
<p>Overcurrent</p>	<ol style="list-style-type: none"> (1) Large discrepancy between power source and voltage (2) Significant voltage drop (3) There is an open phase (4) Reverse rotation (5) Low head; pumping too much liquid (6) Foreign matter clogging pump (7) Motor bearing is worn or damaged 	<ol style="list-style-type: none"> (1) Contact power company for remedy (2) Contact power company for remedy (3) Check power supply Inspect starter & electrical connections (4) Check rotation (5) Adjust discharge valve to desired flow (6) Remove clog from the pump (7) Repair or replace
<p>Pump vibrates; excessive noise during operation.</p>	<ol style="list-style-type: none"> (1) Reverse rotation (2) Pump clogged with foreign matter (3) Piping vibrates 	<ol style="list-style-type: none"> (1) Correct rotation (2) Remove clog from pump (3) Install support for discharge piping



DMLU

Disassembly and Reassembly

1. Disassembly:
 - a.) Unscrew and remove the bolts (120-2), and lift the motor out of the pump casing. Lay it down on its side carefully.
 - b.) Unscrew and remove the impeller bolt (275), then pull the impeller (021) off the motor shaft.
 - c.) Unscrew and remove the oil plug (193) and drain oil from seal chamber.
 - d.) Unscrew and remove the bolts (120-1), and remove the mechanical seal cover (016) carefully. Take care as there may be oil remaining in the seal chamber.
 - d.) Remove the mechanical seal carefully to keep from damaging the seal faces.

2. Reassembly:
 - a.) Perform the above instructions in reverse order, replacing the o-ring, seal washer and gasket.

Note 1: After reassembly to the point of installing impeller on the shaft, turn the impeller by hand to make sure that it rotates smoothly.

Note 2: It is recommended to use a screw adhesive (LOCTITE 271) on the impeller bolt (275) during reassembly.

Note 3: After installing casing back onto pump, turn the impeller by hand through the pump suction to make sure that it rotates smoothly without rubbing against the wear ring.

DMLU

Sectional view

80DML62.2

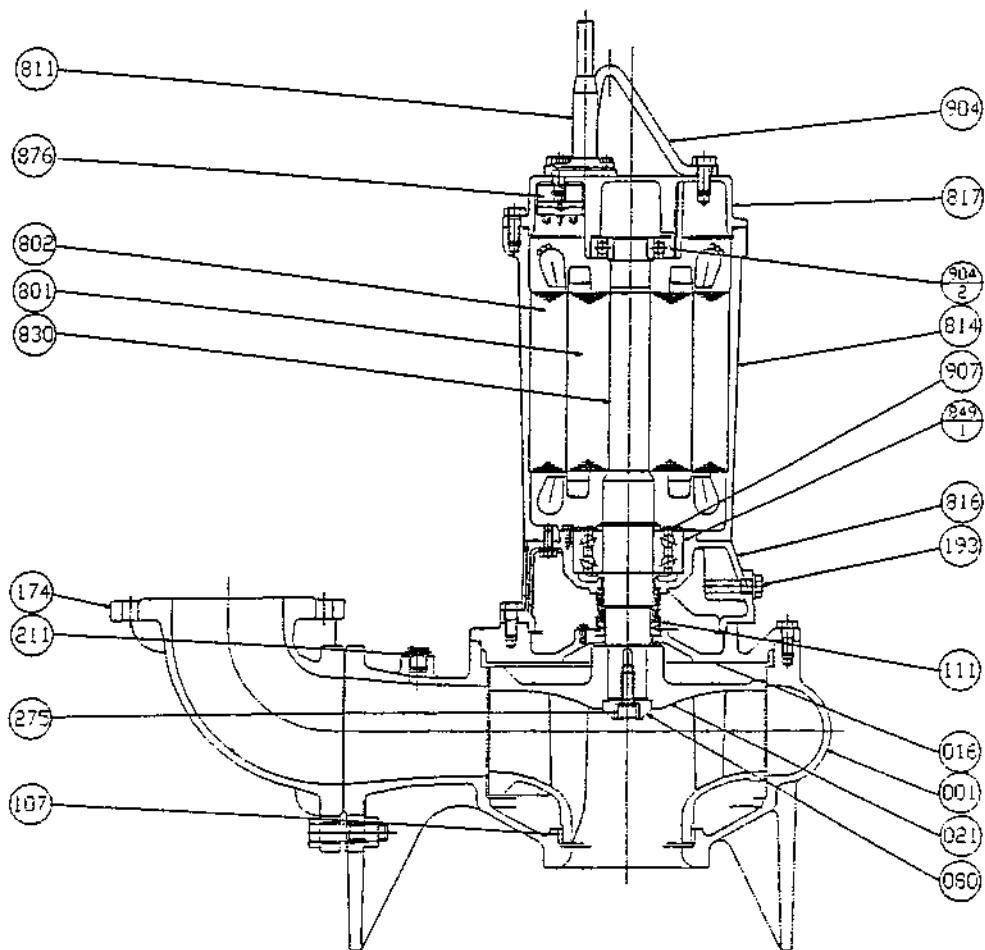

PART NO.	PART NAME	MATERIAL	NO. FOR 1 UNIT
001	CASING	CAST IRON	1
016	MECHANICAL SEAL COVER	CAST IRON	1
021	IMPELLER	CAST IRON	1
080	BUSHING	STAINLESS STEEL	1
107	WEAR RING	BRONZE	1
111	MECHANICAL SEAL	—	1
174	DISCHARGE PIPE	CAST IRON	1 SET
193	OIL PLUG	RUBBER (NBR)	1 SET
211	AIRVENT VALVE	BRASS	1
275	IMPELLER BOLT	STAINLESS STEEL	1
801	ROTOR	—	1
802	STATOR	—	1

PART NO.	PART NAME	MATERIAL	NO. FOR 1 UNIT
811	SUBMERSIBLE CABLE	—	2
814	MOTOR FRAME	CAST IRON	1
816	POWER SIDE BRACKET	CAST IRON	1
817	OPPOSITE SIDE BRACKET	CAST IRON	1
830	SHAFT	STAINLESS STEEL	1
849-1	BALL BEARING	—	1
849-2	BALL BEARING	—	1
876	AUTO CUT	—	3
904	LIFTING HANGER	STEEL	1
907	BEARING COVER	STEEL	1

DMLU

Sectional view

**5 to 10 HP
80DML
100DML
150DML**

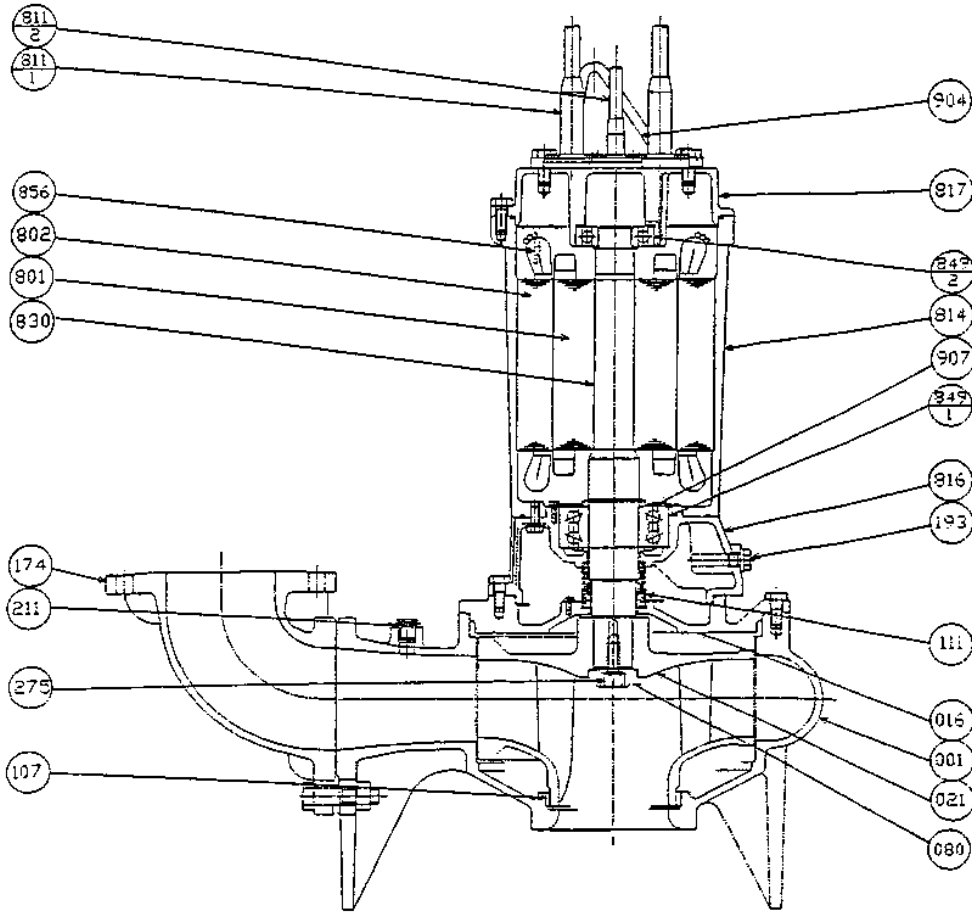

PART NO.	PART NAME	MATERIAL	NO. FOR 1 UNIT
001	CASING	CAST IRON	1
016	MECHANICAL SEAL COVER	CAST IRON	1
021	IMPELLER	CAST IRON	1
080	BUSHING	STEEL	1
107	WEARING RING	BRONZE	1
111	MECHANICAL SEAL	—	1
174	DISCHARGE PIPE	CAST IRON	1
193	OIL PLUG	RUBBER (NBR)	1 SET
211	AIRVENT VALVE	BRASS	1
275	IMPELLER BOLT	STAINLESS STEEL	1
801	ROTOR	—	1
802	STATOR	—	1

PART NO.	PART NAME	MATERIAL	NO. FOR 1 UNIT
811-1	SUBMERSIBLE CABLE (POWER)	—	2
811-2	SUBMERSIBLE CABLE (SIGNAL)	—	1
814	MOTOR FRAME	CAST IRON	1
816	POWER SIDE BRACKET	CAST IRON	1
817	OPPOSITE SIDE BRACKET	CAST IRON	1
830	SHAFT	STAINLESS STEEL	1
849-1	BALL BEARING	—	1
849-2	BALL BEARING	—	1
856	THERMAL PROTECTOR	—	3
904	LIFTING HANGER	STEEL	1
907	BEARING COVER	STEEL	1



DMLU

Sectional view

15 to 30HP
 80DML
 100DML
 150DML

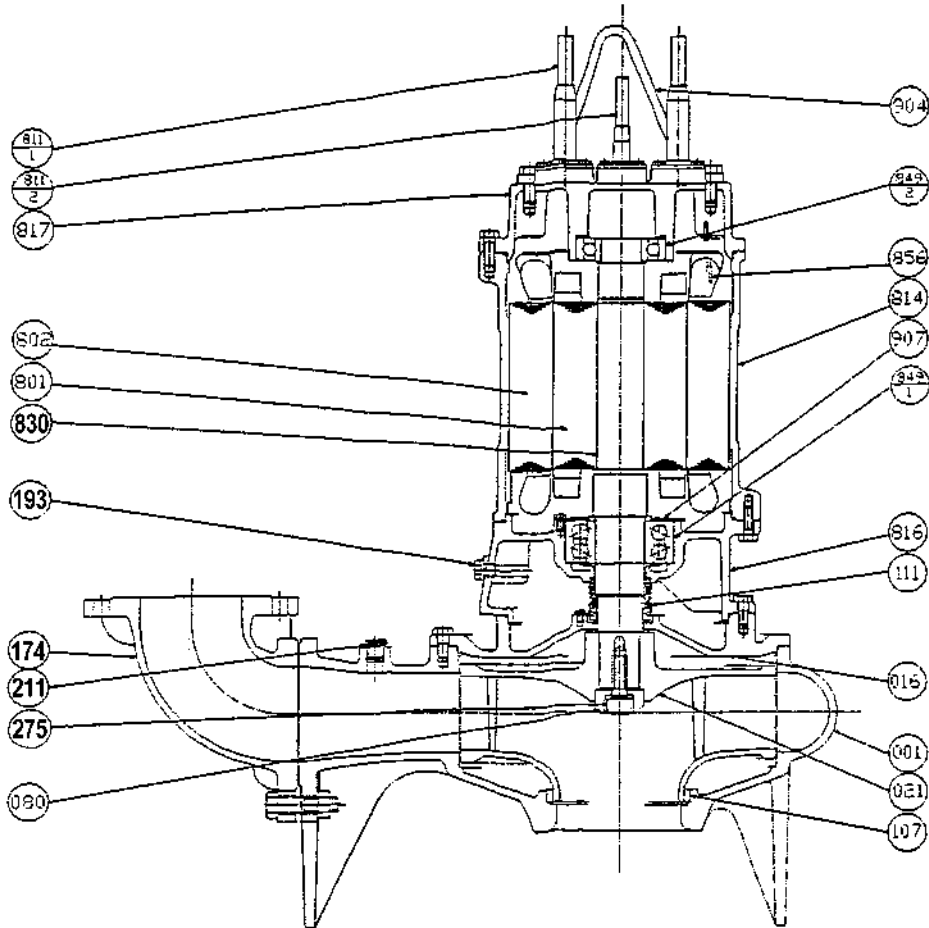

PART NO.	PART NAME	MATERIAL	NO. FOR 1 UNIT
001	CASING	CAST IRON	1
016	MECHANICAL SEAL COVER	CAST IRON	1
021	IMPELLER	CAST IRON	1
080	BUSHING	STEEL	1
107	WEARING RING	BRONZE	1
111	MECHANICAL SEAL	—	1
174	DISCHARGE PIPE	CAST IRON	1
193	OIL PLUG	RUBBER (NBR)	1 SET
211	AIRVENT VALVE	BRASS	1
275	IMPELLER BOLT	STAINLESS STEEL	1
801	ROTOR	—	1
802	STATOR	—	1

PART NO.	PART NAME	MATERIAL	NO. FOR 1 UNIT
811-1	SUBMERSIBLE CABLE (POWER)	—	2
811-2	SUBMERSIBLE CABLE (SIGNAL)	—	1
814	MOTOR FRAME	CAST IRON	1
816	POWER SIDE BRACKET	CAST IRON	1
817	OPPOSITE SIDE BRACKET	CAST IRON	1
830	SHAFT	STAINLESS STEEL	1
849-1	BALL BEARING	—	1
849-2	BALL BEARING	—	1
856	THERMAL PROTECTOR	—	3
904	LIFTING HANGER	STEEL	1
907	BEARING COVER	STEEL	1



DMLU

Warranty

**EBARA INTERNATIONAL CORPORATION
ROCK HILL, SOUTH CAROLINA
COMMERCIAL PUMP/ PRODUCTS LIMITED WARRANTY
(EXCEPT MODEL EPPD SUMP PUMPS)**

Ebara International Corporation, Rock Hill, SC ("EIC-RH") warrants to the original purchaser only ("Customer") that the EIC-RH Commercial Pump/Product ("Pump") will be free of defects in workmanship and material for a period of twelve (12) months from the date of installation or eighteen (18) months from the date of shipment by EIC-RH, whichever comes first, provided that notification of any such defect is promptly given in writing to EIC-RH. Customer may be required at EIC-RH's request to verify that it is the Customer of the Pump and that the Pump was installed and operated in accordance with EIC-RH's instructions.

EIC-RH's sole obligation under this warranty will be to repair or replace with a new or reconditioned Pump, such Pump as has failed or has been found to be defective during the warranty period, or at EIC-RH's sole option, to refund to the customer an equitable part of the purchase price. In no event shall EIC-RH's cost responsibility exceed the initial purchase price paid by the Customer for the Pump.

EIC-RH shall be liable only for the cost of the Pump, or the cost of repair or replacement of any defective Pump. Customer shall be responsible for labor, cost of removal and installation at Customer's premises, transportation and insurance costs to EIC-RH and any other incidental costs.

This warranty is void and does not apply if pump control cable is not properly connected to control panel, if damage is caused by improper installation, improper maintenance, accident, alteration, abuse, misuse or if the Pump has been disassembled prior to warranty evaluation without written authorization from EIC-RH.

Warranty service and information for return procedures will be provided by EIC-RH upon receipt of written notice describing the defect or problem to:

Ebara International Corporation
Warranty/Claims
1651 Cedar Line Drive
Rock Hill, SC 29730
803-327-5005 Phone
803-327-5097 Fax

THE FOREGOING WARRANTY IS THE SOLE AND EXCLUSIVE WARRANTY ON THIS PUMP, AND ALL OTHER WARRANTIES, EXPRESSED OR IMPLIED, INCLUDING ANY WARRANTY OF MERCHANTABILITY OR FITNESS FOR A PARTICULAR PURPOSE, ARE DISCLAIMED AND EXCLUDED FROM THE TERMS OF THIS WARRANTY. EIC-RH'S SOLE OBLIGATION IN CASE OF ANY DEFECT WILL BE TO PROVIDE THE WARRANTY SERVICE SPECIFIED ABOVE. THE FOREGOING IS CUSTOMER'S SOLE AND EXCLUSIVE REMEDY, WHETHER IN CONTRACT, TORT OR OTHERWISE AND EIC-RH SHALL NOT BE LIABLE FOR ANY CONSEQUENTIAL OR INCIDENTAL DAMAGES OF ANY KIND WHATSOEVER.

