

Model CLU

EBARA PRO Cast Sewage Pumps

Sectional View

Single Phase

1 to 5HP

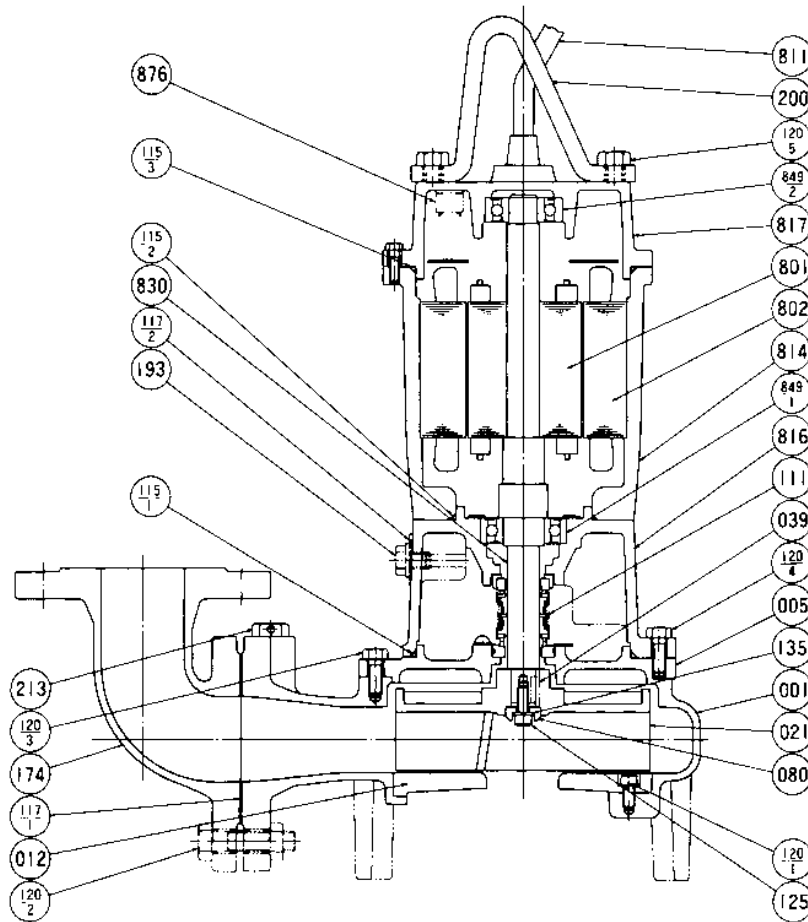

PART NO.	PART NAME	MATERIAL	ASTM, AISI CODE	NO. FOR 1 UNIT	PART NO.	PART NAME	MATERIAL	ASTM, AISI CODE	NO. FOR 1 UNIT
001	CASING	CAST IRON	A48 Class 30	1	125	BOLT	304 STAINLESS	AISI304	1
005	INTERMEDIATE CASING	CAST IRON	A48 Class 30	1	135	WASHER	304 STAINLESS	AISI304	1
012	SUCTION COVER	CAST IRON	A48 Class 30	1	174	DISCHARGE ELBOW	CAST IRON	A48 Class 30	1
021	IMPELLER	CAST IRON	A48 Class 30	1	193	OIL PLUG	316 STAINLESS	AISI316	1
039	KEY	420 STAINLESS	AISI420	1	200	LIFTING HANGER	STEEL	A283 Grade D	1
080	BUSHING	STEEL	A283 Grade D	1	213	AIR VENT VALVE	BRASS	B36 NO. 272	1
†111	MECHANICAL SEAL	—		1 SET	801	ROTOR	—		1
†115-1	O-RING	RUBBER (NBR)		1	802	STATOR	—		1
†115-2	O-RING	RUBBER (NBR)		1	811	SUBMERSIBLE CABLE	—		1
†115-3	O-RING	RUBBER (NBR)		1	814	MOTOR FRAME	CAST IRON	A48 Class 30	1
†117-1	GASKET			1	816	BRACKET	CAST IRON	A48 Class 30	1
†117-2	GASKET			1	817	BRACKET	CAST IRON	A48 Class 30	1
120-1	BOLT	304 STAINLESS	AISI304	3 or 4	830	SHAFT	403 STAINLESS	AISI403	1
120-2	BOLT	304 STAINLESS	AISI304	4	†849-1	BALL BEARING	—		1
120-3	BOLT	304 STAINLESS	AISI304	4 or 8	†849-2	BALL BEARING	—		1
120-4	BOLT	304 STAINLESS	AISI304	4	876	MOTOR PROTECTOR	—		1
120-5	BOLT	304 STAINLESS	AISI304	2					

Motors are purchased as a complete unit.

†: Recommended spare parts.



EBARA Fluid Handling
www.pumpsebara.com
 (t) 803 327-5005 • (f) 803 327-5097

Model CLU

EBARA PRO Cast Sewage Pumps

Sectional View

Three Phase

1 to 2HP

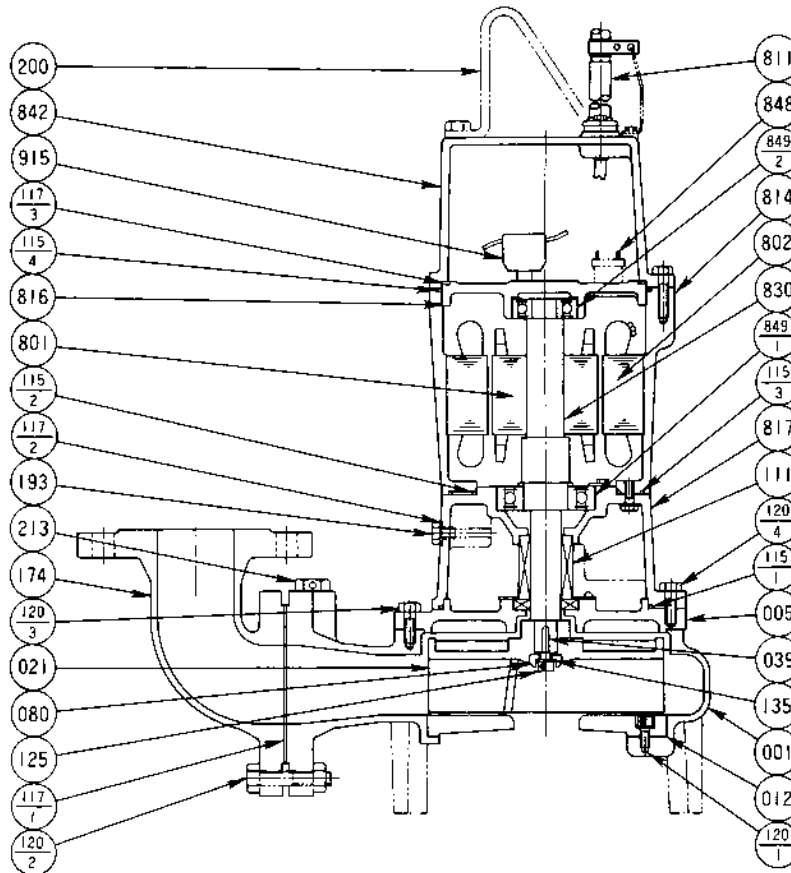

PART NO.	PART NAME	MATERIAL	ASTM, AISI CODE	NO. FOR 1 UNIT	PART NO.	PART NAME	MATERIAL	ASTM, AISI CODE	NO. FOR 1 UNIT
001	CASING	CAST IRON	A48 Class 30	1	125	BOLT	304 STAINLESS	AISI304	1
005	INTERMEDIATE CASING	CAST IRON	A48 Class 30	1	135	WASHER	304 STAINLESS	AISI304	1
012	SUCTION COVER	CAST IRON	A48 Class 30	1	174	DISCHARGE ELBOW	CAST IRON	A48 Class 30	1
021	IMPELLER	CAST IRON	A48 Class 30	1	193	OIL PLUG	316 STAINLESS	AISI316	1
039	KEY	420 STAINLESS	AISI420	1	200	LIFTING HANGER	STEEL	A283 Grade D	1
080	BUSHING	STEEL	A283 Grade D	1	213	AIR VENT VALVE	BRASS	B36 NO. 272	1
†111	MECHANICAL SEAL	—		1 SET	801	ROTOR	—		1
†115-1	O-RING	RUBBER (NBR)		1	802	STATOR	—		1
†115-2	O-RING	RUBBER (NBR)		1	811	SUBMERSIBLE CABLE	—		1
†115-3	O-RING	RUBBER (NBR)		1	814	MOTOR FRAME	CAST IRON	A48 Class 30	1
†115-4	O-RING	RUBBER (NBR)		1	816	BRACKET	CAST IRON	A48 Class 30	1
†117-1	GASKET			1	817	BRACKET	CAST IRON	A48 Class 30	1
†117-2	GASKET			1	830	SHAFT	403 STAINLESS	AISI403	1
†117-3	GASKET	RUBBER (NBR)		1	842	MOTOR COVER	CAST IRON	A48 Class 30	1
120-1	BOLT	304 STAINLESS	AISI304	3 or 4	848	MOTOR PROTECTOR	—		1
120-2	BOLT	304 STAINLESS	AISI304	4	†849-1	BALL BEARING	—		1
120-3	BOLT	304 STAINLESS	AISI304	4 or 8	†849-2	BALL BEARING	—		1
120-4	BOLT	304 STAINLESS	AISI304	4	915	EXTERNAL TERMINAL	—		1

Motors are purchased as a complete unit.

Parts No. 115-2 is not installed for 2HP

Parts No. 117-3 is not installed for 1HP

†: Recommended spare parts.



EBARA Fluid Handling

www.pumpsebara.com

(t) 803 327-5005 • (f) 803 327-5097