

**EBARA Submersible Sewage Pumps**

**DSC3/DSCA3**

**Sectional View**

Project: \_\_\_\_\_ Model: \_\_\_\_\_ Chk'd: \_\_\_\_\_ Date: \_\_\_\_\_

**Model DSC3 with Quick Discharge Connector**

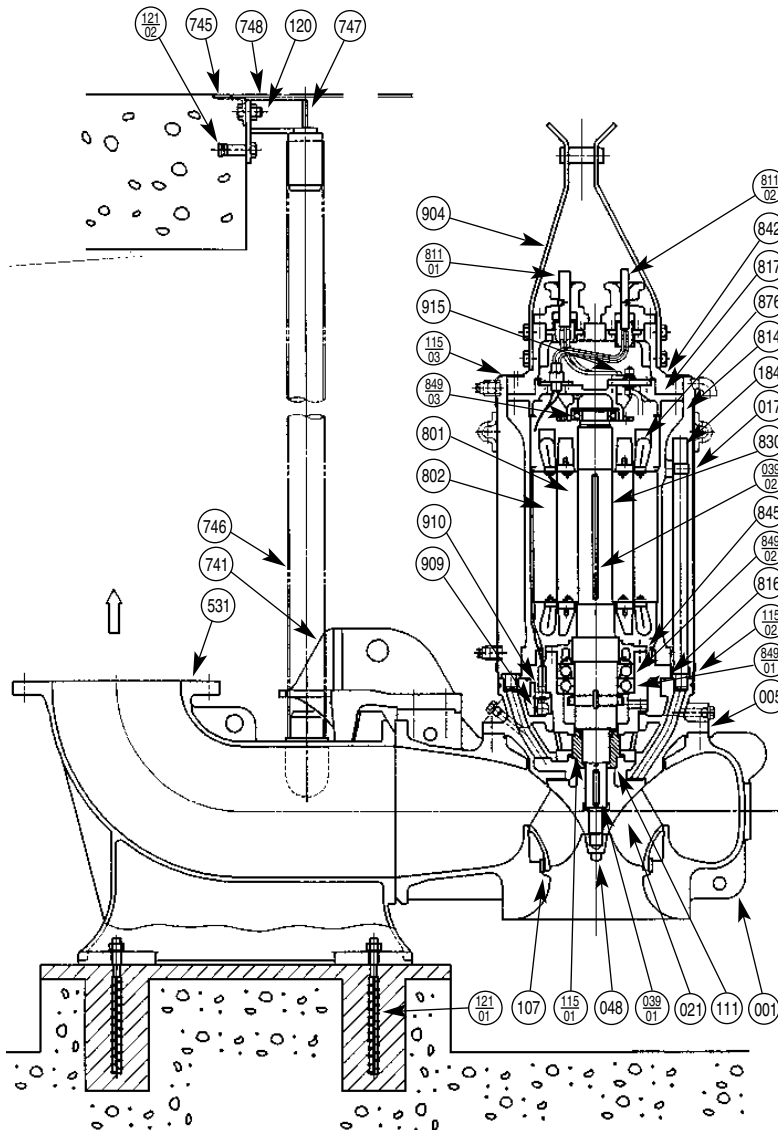

| Part No. | Part Name                 | Material     | ASTM, AISI Code    | No. for 1 Unit |
|----------|---------------------------|--------------|--------------------|----------------|
| 915      | Terminal Board            | -            | -                  | 1              |
| 910      | Leakage Detector Support  | Cast Iron    | ASTM A48 CL.30     | 1              |
| 909      | Leakage Detector          | -            | -                  | 1              |
| 904      | Lifting Hanger            | Steel        | ASTM A 283 GR.D    | 1              |
| 876      | Thermal Protector         | -            | -                  | 1              |
| 849-03   | Ball Bearing              | -            | -                  | 1              |
| 849-02   | Ball Bearing              | -            | -                  | 1              |
| 849-01   | Ball Bearing              | -            | -                  | 1              |
| 845      | Bearing Cover             | Cast Iron    | ASTM A48 CL.30     | 1              |
| 842      | Motor Cover               | Cast Iron    | ASTM A48 CL.35     | 1              |
| 830      | Shaft                     | Stainless    | AISI 403           | 1              |
| 817      | Opposite Side Bracket     | Cast Iron    | ASTM A48 CL.35     | 1              |
| 816      | Power Side Bracket        | Cast Iron    | ASTM A48 CL.35     | 1              |
| 814      | Motor Frame               | Cast Iron    | ASTM A48 CL.35     | 1              |
| 811-02   | Control Cord              | -            | -                  | 1              |
| 811-01   | Line Cord                 | -            | -                  | 1              |
| 802      | Stator                    | -            | -                  | 1              |
| 801      | Rotor                     | -            | -                  | 1              |
| 748      | Floor Plate               | Steel        | ASTM A283 GR.D     | 1              |
| 747      | Guide Pipe Support        | Steel        | ASTM A283 GR.D     | 1              |
| 746      | Guide Pipe                | Stainless    | AISI 304           | 2              |
| 745      | Floor Frame               | Steel        | ASTM A283 GR.D     | 1              |
| 741      | Sliding Guide             | Ductile Iron | ASTM A536 60-40-18 | 1              |
| 531      | Quick Discharge Connector | Cast Iron    | ASTM A48 CL.35     | 1              |
| 184      | Cooling Water Pipe        | SGP          | ASTM A120          | 4              |
| 121-02   | Hole-In Anchor            | Stainless    | AISI 304           | 2              |
| 121-01   | Anchor Bolt               | Stainless    | AISI 304           | 4              |
| 120      | Holder Bolt               | Stainless    | AISI 304           | 2              |
| 115-03   | O-Ring                    | NBR          | -                  | 1              |
| 115-02   | O-Ring                    | NBR          | -                  | 1              |
| 115-01   | O-Ring                    | NBR          | -                  | 1 Set          |
| 111      | Mechanical Seal           | -            | -                  | 1              |
| 107      | Casing Ring               | Stainless    | AISI 403           | 1              |
| 048      | Impeller Nut              | Stainless    | AISI 403           | 1              |
| 039-02   | Key                       | S50C         | AISI 1050          | 1              |
| 039-01   | Key                       | Stainless    | AISI 420           | 1              |
| 021      | Impeller *                | Cast Iron    | ASTM A48 CL.35     | 1              |
| 017      | Cooling Jacket            | Steel        | ASTM A283 GR.D     | 1              |
| 005      | Intermediate Casing       | Cast Iron    | ASTM A48 CL.35     | 1              |
| 001      | Pump Casing               | Cast Iron    | ASTM A48 CL.35     | 1              |

\* Ductile Iron for Models: E1262-1780  
 F1102-1780  
 F1302-1780  
 G1012-1780  
 G1102-1780  
 G1232-1780  
 F1593-1180



**EBARA Submersible Sewage Pumps**

**DSC3/DSCA3**

**Sectional View**

Project: \_\_\_\_\_ Model: \_\_\_\_\_ Chk'd: \_\_\_\_\_ Date: \_\_\_\_\_

**Model DSCA3 Drypit Application**

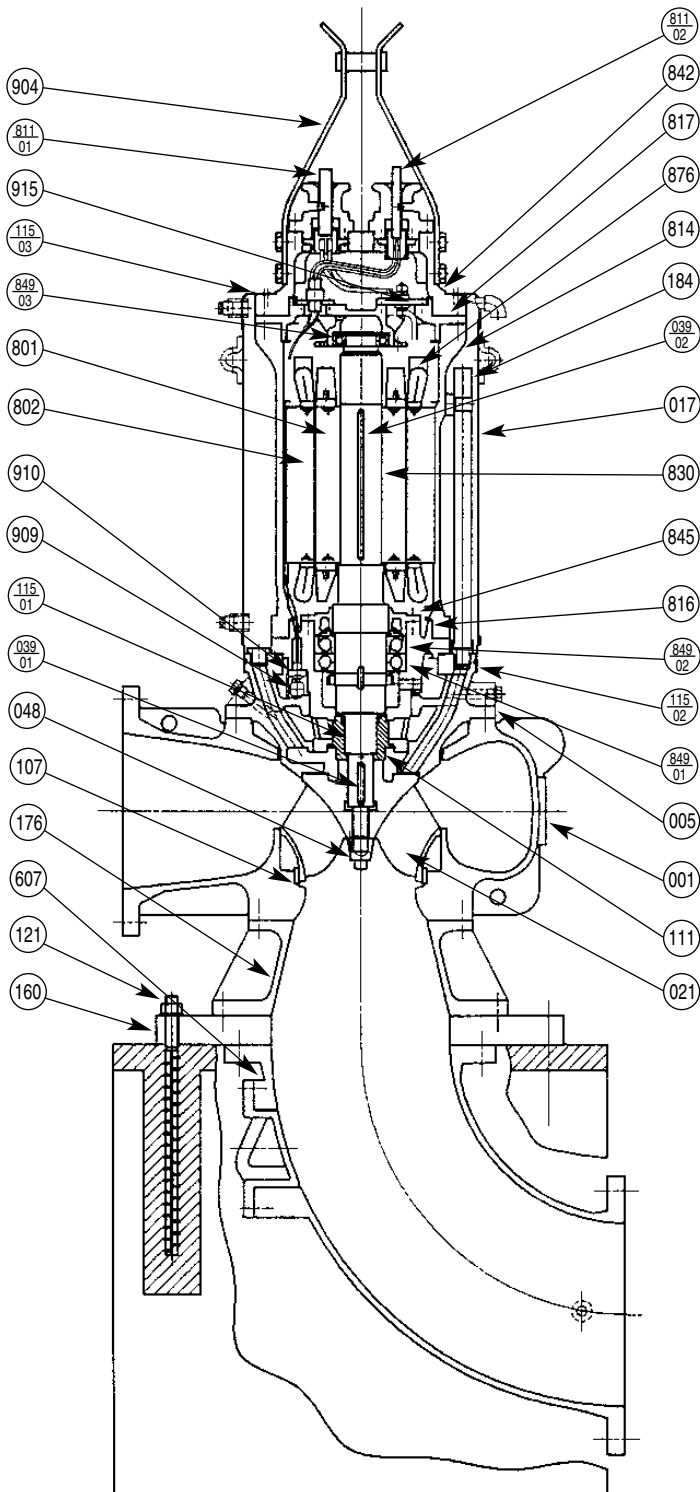

| Part No. | Part Name                | Material  | ASTM, AISI Code | No. for 1 Unit |
|----------|--------------------------|-----------|-----------------|----------------|
| 915      | Terminal Board           | -         | -               | 1              |
| 910      | Leakage Detector Support | Cast Iron | ASTM A48 CL.30  | 1              |
| 909      | Leakage Detector         | -         | -               | 1              |
| 904      | Lifting Hanger           | Steel     | ASTM A 283 GR.D | 1              |
| 876      | Thermal Protector        | -         | -               | 1              |
| 849-03   | Ball Bearing             | -         | -               | 1              |
| 849-02   | Ball Bearing             | -         | -               | 1              |
| 849-01   | Ball Bearing             | -         | -               | 1              |
| 845      | Bearing Cover            | Cast Iron | ASTM A48 CL.30  | 1              |
| 842      | Motor Cover              | Cast Iron | ASTM A48 CL.35  | 1              |
| 830      | Shaft                    | Stainless | AISI 403        | 1              |
| 817      | Opposite Side Bracket    | Cast Iron | ASTM A48 CL.35  | 1              |
| 816      | Power Side Bracket       | Cast Iron | ASTM A48 CL.35  | 1              |
| 814      | Motor Frame              | Cast Iron | ASTM A48 CL.35  | 1              |
| 811-02   | Control Cord             | -         | -               | 1              |
| 811-01   | Line Cord                | -         | -               | 1              |
| 802      | Stator                   | -         | -               | 1              |
| 801      | Rotor                    | -         | -               | 1              |
| 607      | Suction Elbow            | Cast Iron | ASTM A48 CL.35  | 1              |
| 184      | Cooling Water Pipe       | SGP       | ASTM A120       | 4              |
| 176      | Conical Pipe             | Cast Iron | ASTM A48 CL.35  | 1              |
| 160      | Base                     | Steel     | ASTM A283 GR.D  | 1              |
| 121      | Anchor Bolt              | Stainless | AISI 304        | 4              |
| 115-03   | O-Ring                   | NBR       | -               | 1              |
| 115-02   | O-Ring                   | NBR       | -               | 1              |
| 115-01   | O-Ring                   | NBR       | -               | 1 Set          |
| 111      | Mechanical Seal          | -         | -               | 1              |
| 107      | Casing Ring              | Stainless | AISI 403        | 1              |
| 048      | Impeller Nut             | Stainless | AISI 403        | 1              |
| 039-02   | Key                      | S50C      | AISI 1050       | 1              |
| 039-01   | Key                      | Stainless | AISI 420        | 1              |
| 021      | Impeller*                | Cast Iron | ASTM A48 CL.35  | 1              |
| 017      | Cooling Jacket           | Steel     | ASTM A283 GR.D  | 1              |
| 005      | Intermediate Casing      | Cast Iron | ASTM A48 CL.35  | 1              |
| 001      | Pump Casing              | Cast Iron | ASTM A48 CL.35  | 1              |

\* Ductile Iron for Models: E1262-1780  
 F1102-1780  
 F1302-1780  
 G1012-1780  
 G1102-1780  
 G1232-1780  
 F1593-1180

