

Contents

Model

- 50DVU6.75S
- 50DVU6.75
- 50DVU61.5S
- 50DVU61.5
- 50DVU62.2S
- 80DVU61.5S
- 80DVU61.5
- 80DVCU62.2S
- 80DVBU62.2S
- 80DVBU63.7S
- 80DVCU63.7S
- 100DVU63.7S

Section	Page
Specifications	2-123
Selection Chart	2-124
Performance Curves	2-125
Outline Drawings	2-130
Sectional View	2-134
QDC Information	2-278
Technical Information	2-289.1
material specification	
impeller description	
motor protection	
cable entry	
paint specifications	
mechanical seal	
general	
Motor Data	2-315.1
motor electrical specifications	
cable data	
wiring diagrams	
motor electrical data	

Model Designation

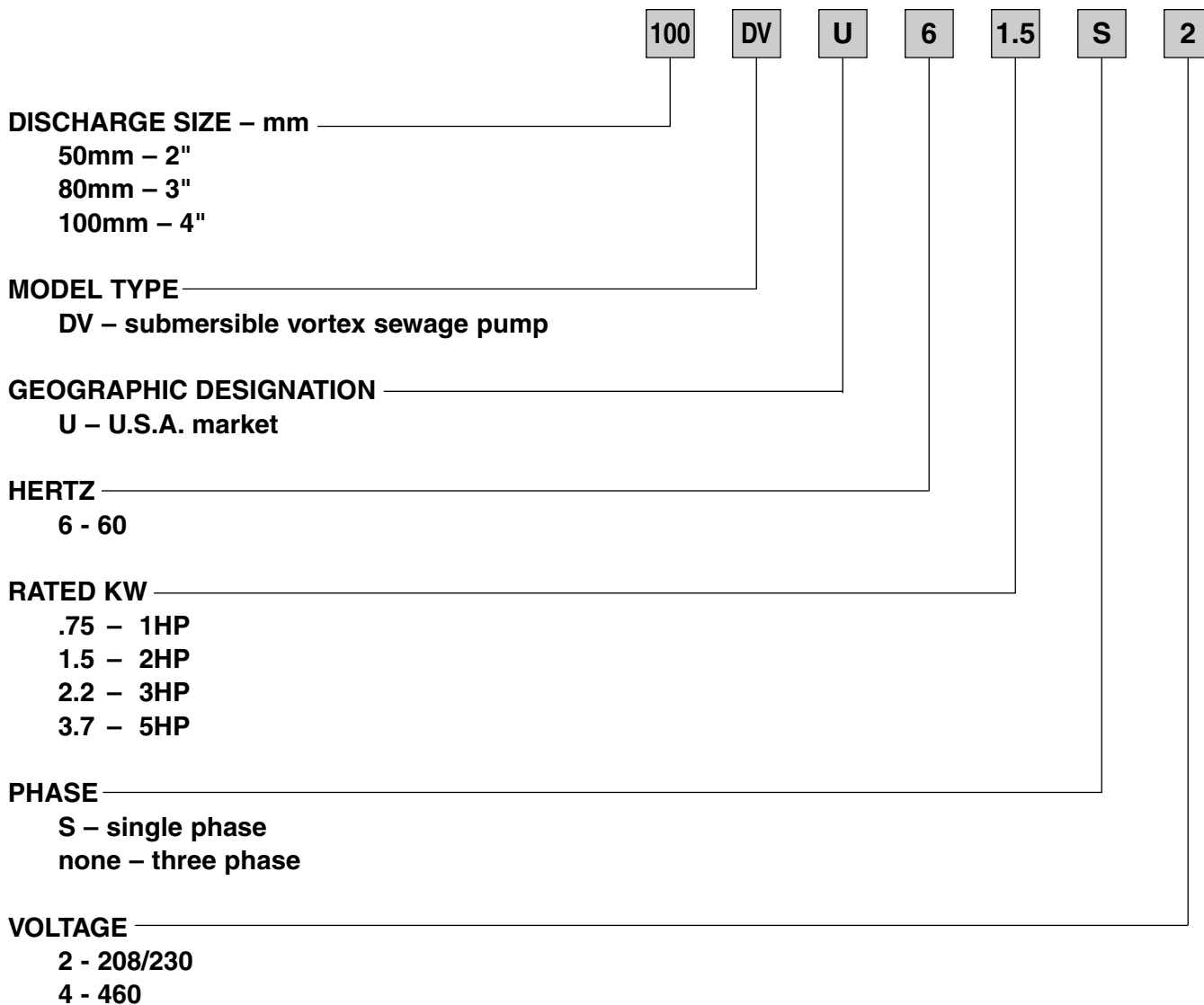

Specifications

Model DVU
Specifications

	Standard	Optional
Size	2, 3, 4 inch	
Range of HP	1 to 2 HP Three Phase 1 to 5 HP Single Phase	
Range of Performance	Capacity 16 to 430 GPM Head 9 to 66 feet	
Limitation Maximum Water Temperature	104°F (40°C)	
Synchronous Speed	1800 RPM	
Materials Casing Impeller Shaft Motor Frame Fastener	Cast Iron Cast Iron 403 Stainless Steel Cast Iron 304 Stainless Steel	
Mechanical Seal Material – Upper Side Material – Lower Side Impeller Type Bearing Motor Single Phase Three Phase Service Factor Motor Protection Single Phase Three Phase Accessories	Double Mechanical Seal Carbon/Ceramic Silicon Carbide/Silicon Carbide Recessed Vortex Impeller Prelubricated Ball Bearing Air-filled, Insulation Class F 208/230V 208/230/460V 1.15 Built-in Auto Cut - overload, no load, out of phase, and single phasing protection Submersible cable 33 ft.	66 ft. QDC System

Specifications

A. General:

Provide submersible vortex sewage pumps suitable for continuous duty operation underwater without loss of water-tight integrity to a depth of 65 feet. If mounted on a guide rail system, design shall be such that the pump will be automatically connected to the discharge piping when lowered into place on the discharge connection. The pump shall be easily removable for inspection or service, requiring no bolts, nuts, or other fasteners to be disconnected, or the need for personnel to enter the wet well. The motor and pump shall be designed, manufactured, and assembled by the same manufacturer.

B. Manufacturer:

EBARA International Corporation

C. Pump Characteristics:

Pumps shall conform to the following requirements:

Number of units	
Design flow (gpm)	
Design TDH (ft)	
Minimum shut off head (ft)	
RPM	1800
Maximum HP	
Minimum efficiency at design (%)	
Minimum power factor at design (%)	
Voltage/HZ	208/230V, 460V / 60
Phase	

D. Pump Construction:

All major parts of the pumping unit(s) including casing, impeller, motor frame and discharge elbow shall be manufactured from gray cast iron, ASTM A-48 Class 30. Castings shall have smooth surfaces devoid of blow holes or other casting irregularities. Casing design shall be centerline discharge with a large radius on the cut water to prevent clogging. Units shall be furnished with a discharge elbow and 125 lb. flat face ANSI flange. All exposed bolts and nuts shall be 304 stainless steel. All mating surfaces of major components shall be machined and fitted with NBR O-rings where watertight sealing is required. Machining and fitting shall be such that sealing is accomplished by automatic compression of O-rings in two planes and O-ring contact is made on four surfaces without the requirement of specific torque limits. Internal and external surfaces are prepared to SPPC-VISI-SP-3-63 then coated with a zinc-chromate primer. The external surfaces are then coated with a H.B. Tnemecol 46-465 Coal Tar paint.

Impeller shall be a recessed, semi-vortex, multi-vane design. The impeller design shall include back pump out vanes to reduce the pressure and entry of foreign materials into the mechanical seal area. The inlet edge of the impeller vanes shall be angled toward the impeller periphery so as to facilitate the release of objects that might otherwise clog the pump. Impellers shall be direct connected to the motor shaft with a slip fit, key driven, and secured with an impeller bolt.

Double mechanical seals operating in an oil bath shall be provided on all units. The oil filled seal chamber shall be designed to prevent over-filling and include an anti-vortexing vane to insure proper lubrication of both seal faces. Lower face materials shall be silicon carbide vs. silicon carbide, upper faces carbon vs. ceramic, NBR elastomers, and 304SS hardware. Seal system shall not rely on pumping medium for lubrication.



Specifications

E. Motor Construction:

The pump motor shall be an air filled induction type with a squirrel cage rotor, shell type design, built to NEMA MG-1, Design B specifications. Stator windings shall be copper, insulated with moisture resistant Class F insulation, rated for 311°F. The stator shall be dipped and baked three times in Class F varnish and heat shrunk fitted into the stator housing. Rotor bars and short circuit rings shall be manufactured of cast aluminum. Motor shaft shall be one piece AISI403 material, rotating on two permanently lubricated ball bearings designed for a minimum B-10 life of 60,000 hours. Motor service factor shall be 1.15 and capable of up to 20 starts per hour. The motor shall be designed for continuous duty pumping at a maximum sump temperature of 104°F. Voltage and frequency tolerances shall be a maximum 10 / 5% respectively. Junction area shall include a terminal board for power connections on all three (3) phase units. Motor protection shall be provided by an auto-cut device located directly over the windings to provide protection from single phasing, low voltage, phase imbalance, locked rotor, and no load or run dry conditions. Motor shall be non-overloading over the entire performance curve and be able to operate at full load intermittently while unsubmerged without damage to the unit.

Power cable jacket shall be manufactured of an oil resistant chloroprene rubber material, designed for submerged applications. Cable shall be watertight to a depth of a least 65'. Cable entry shall be composed of a one piece, vulcanized, three way mechanical sealing system with a thick molded shoulder with increasing cable diameters to resist fatigue from bending forces. The molded shoulder, acts as the primary and secondary sealing points. This system shall also prevent leakage into the motor housing due to capillary action through the insulation if the cable is damaged or cut. A metallic plate shall be utilized to clamp the entry system to the motor housing. Strain relief shall be accomplished by clamping and attaching the cable with chain to the motor housing.

F. Guide Rail system:

Design shall include two (2) 304SS schedule 40 guide rails sized to mount directly to the quick discharge connector, QDC, at the floor of the wetwell and to a guide rail bracket at the top of the wetwell below the hatch opening, (refer to project drawings). Intermediate guide brackets are recommended for rail lengths over 15 feet. Guide rails are not part of the pump package and shall be supplied by others.

The QDC shall be manufactured of cast iron, ASTM A48 Class 30. It shall be designed to adequately support the guide rails, discharge piping, and pumping unit under both static and dynamic loading conditions with support legs that are suitable for anchoring it to the wetwell floor. The face of the inlet QDC flange shall be perpendicular to the floor of the wetwell. The discharge flange of the QDC shall conform to ANSI B16.1 Class 125.

The pump design shall include an integral self-aligning sliding bracket. Sealing of the pumping unit to the QDC shall be accomplished by a single, linear, downward motion of the pump. The entire weight of the pump unit shall be guided to and wedged tightly against the inlet flange of the QDC, making metal to metal contact with the pump discharge forming a seal without the use of bolts, gaskets or O-rings.

Lifting chain shall be galvanized (stainless steel) suitable for removing and installing the pump unit.

Selection Chart

Model DVU
Selection chart

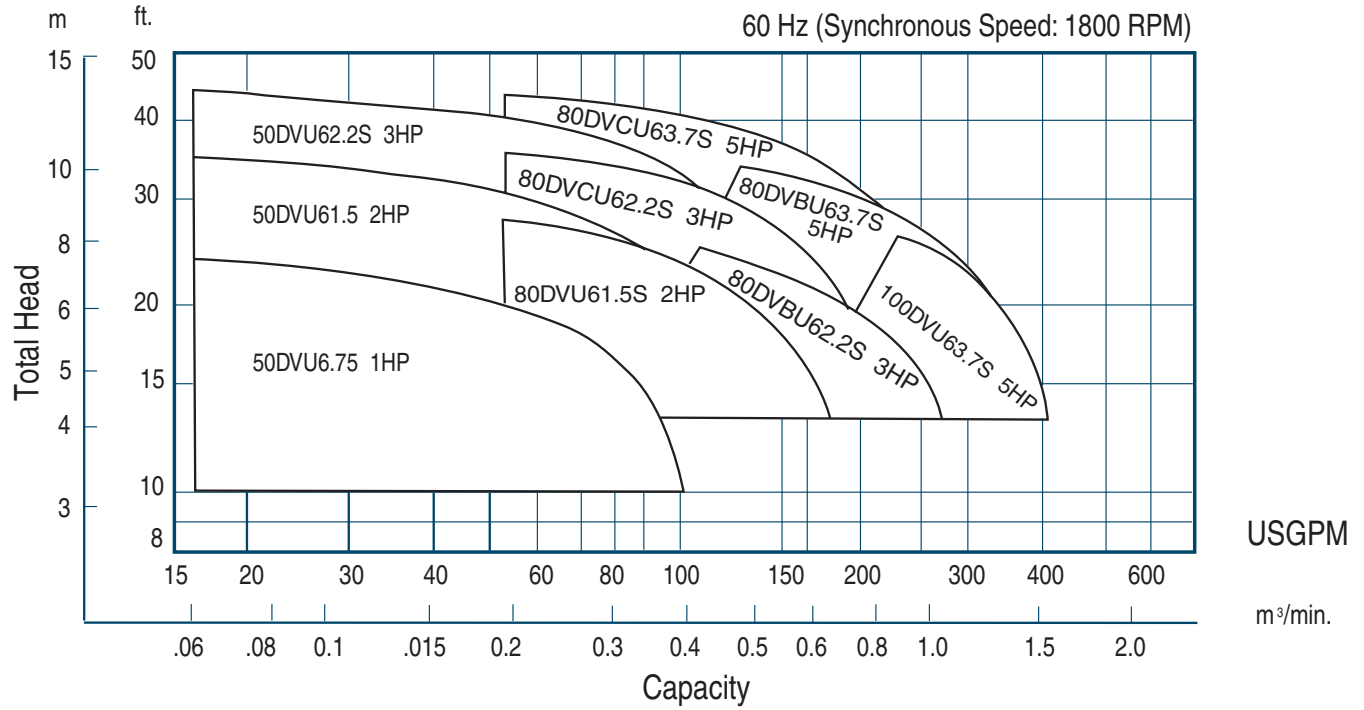

Performance Curves

Project: _____ GPM: _____ TDH: _____ EFF: _____ HP: _____ Chk'd: _____ Date: _____

50DV6.75S 50DV6.75 (1HP) Synchronous Speed: 1800 RPM

2 inch Discharge

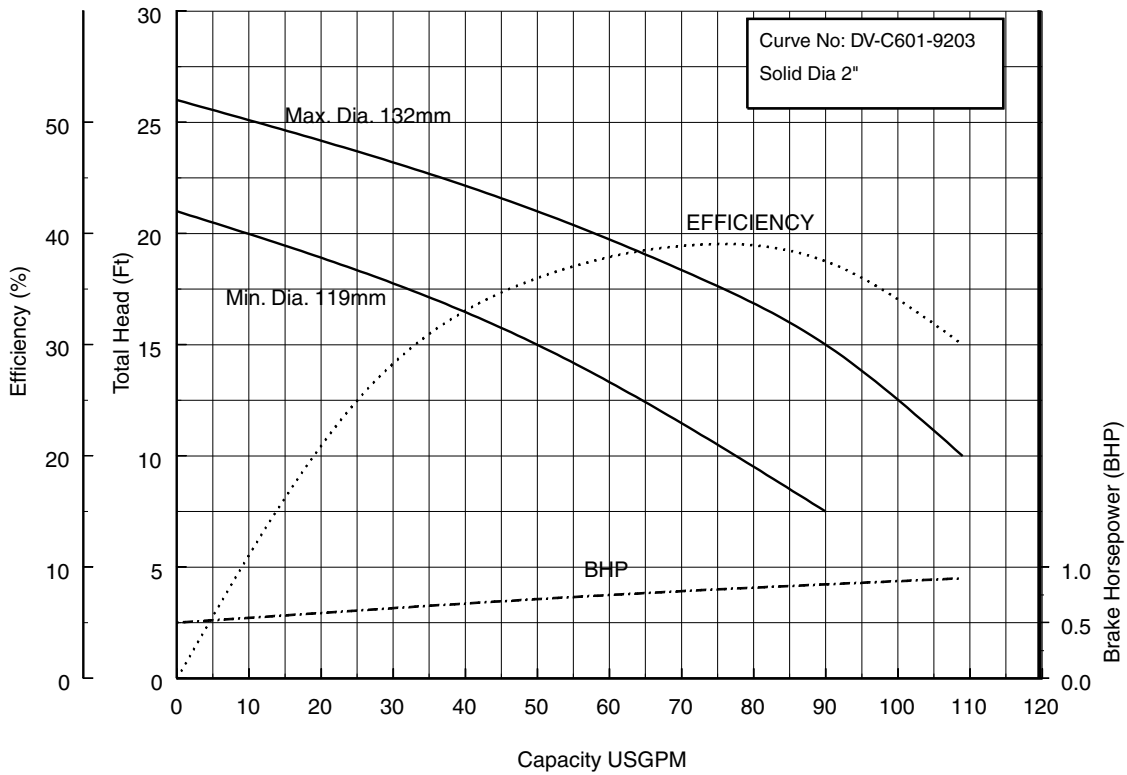

50DV61.5S 50DV61.5 (2HP) Synchronous Speed: 1800 RPM

2 inch Discharge

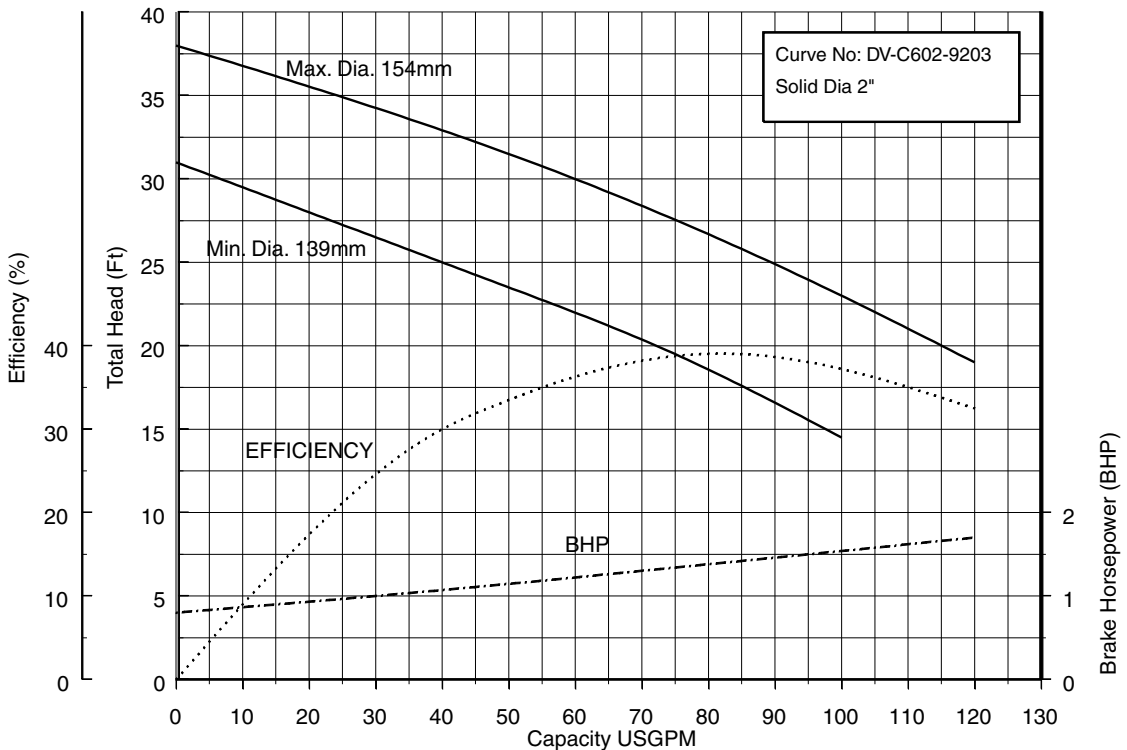

Performance Curves

Project: _____ GPM: _____ TDH: _____ EFF: _____ HP: _____ Chk'd: _____ Date: _____

50DV62.2S (3HP) Synchronous Speed: 1800 RPM

2 inch Discharge

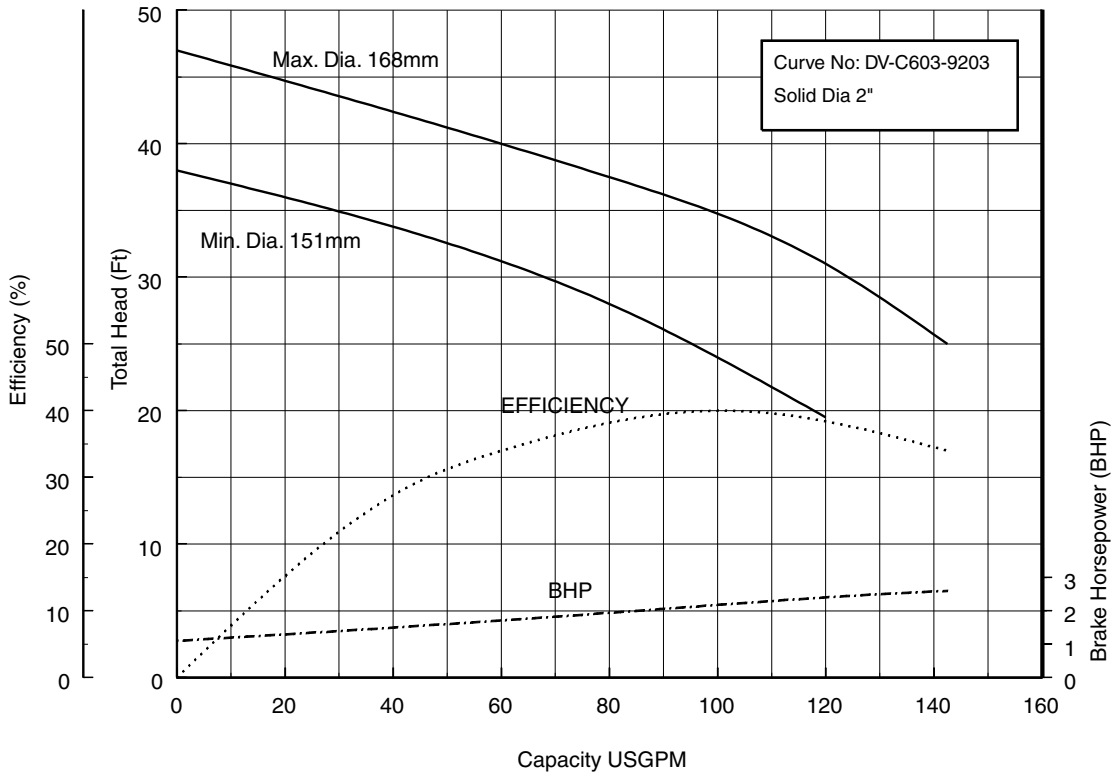

80DV61.5S 80DV61.5 (2HP) Synchronous Speed: 1800 RPM

3 inch Discharge

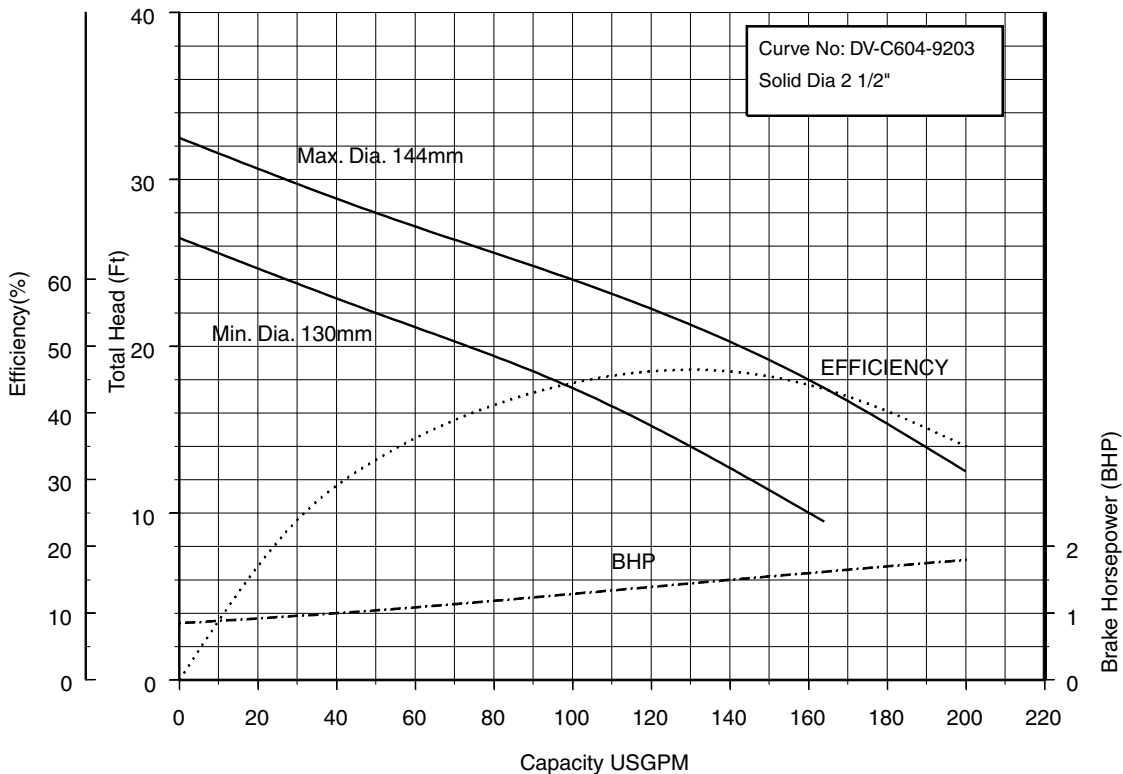

Performance Curves

Project: _____ GPM: _____ TDH: _____ EFF: _____ HP: _____ Chk'd: _____ Date: _____

80DVB62.2S (3HP) Synchronous Speed: 1800 RPM

3 inch Discharge

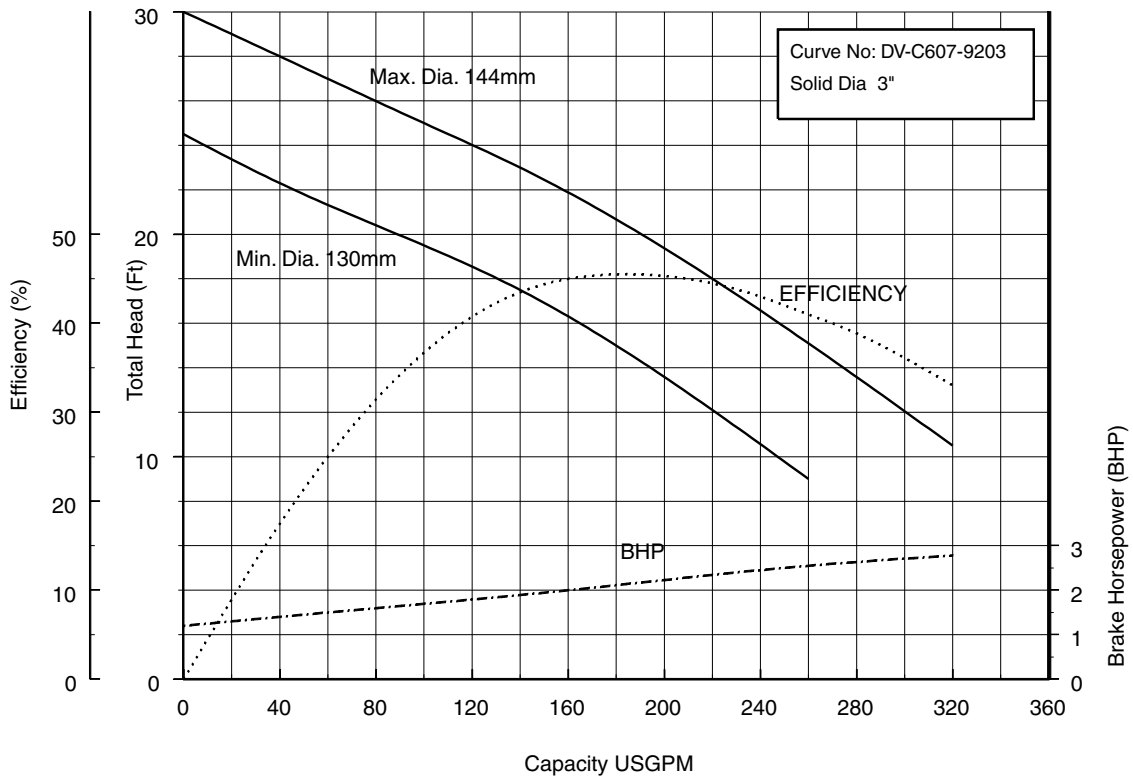

80DVC62.2S (3HP) Synchronous Speed: 1800 RPM

3 inch Discharge

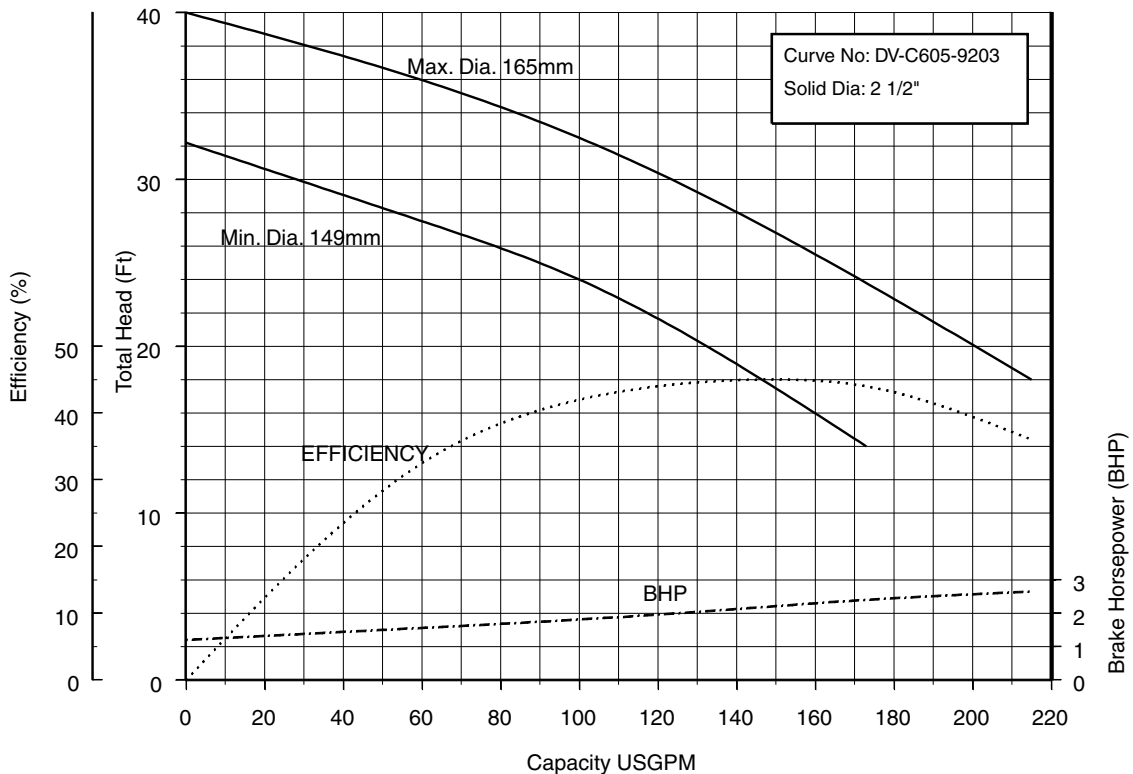

Performance Curves

Project: _____ GPM: _____ TDH: _____ EFF: _____ HP: _____ Chk'd: _____ Date: _____

80DVB63.7S (5HP) Synchronous Speed: 1800 RPM

3 inch Discharge

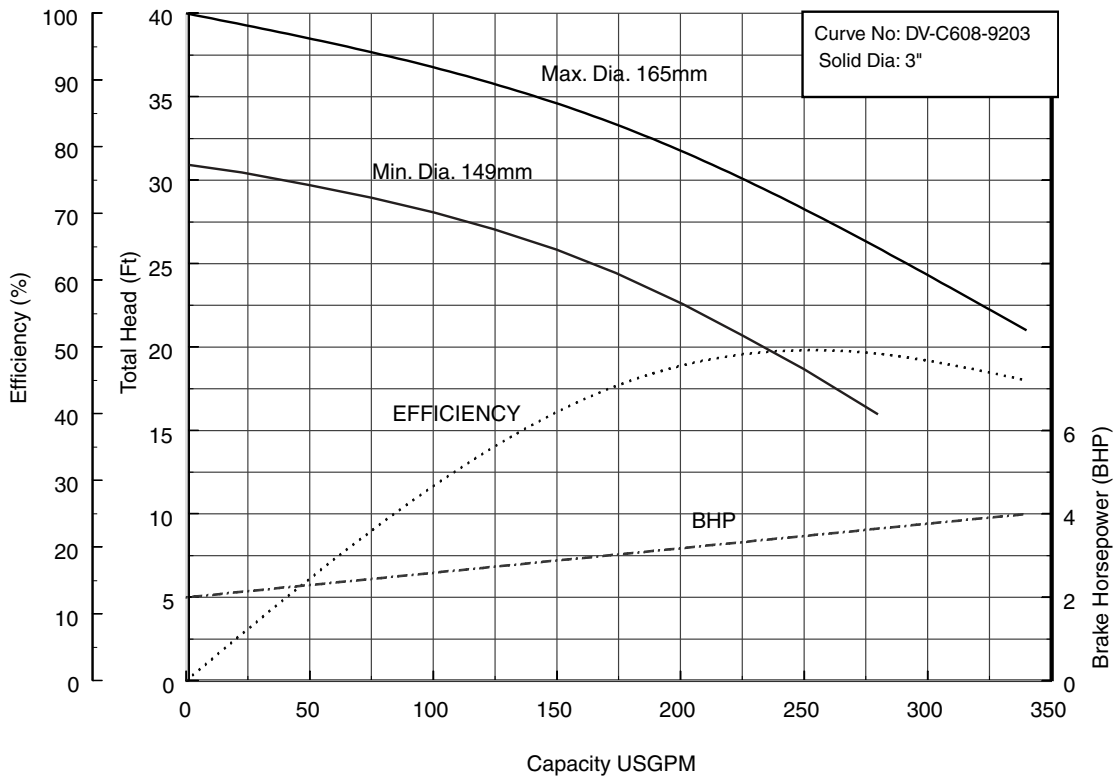

80DVC63.7S (5HP) Synchronous Speed: 1800 RPM

3 inch Discharge

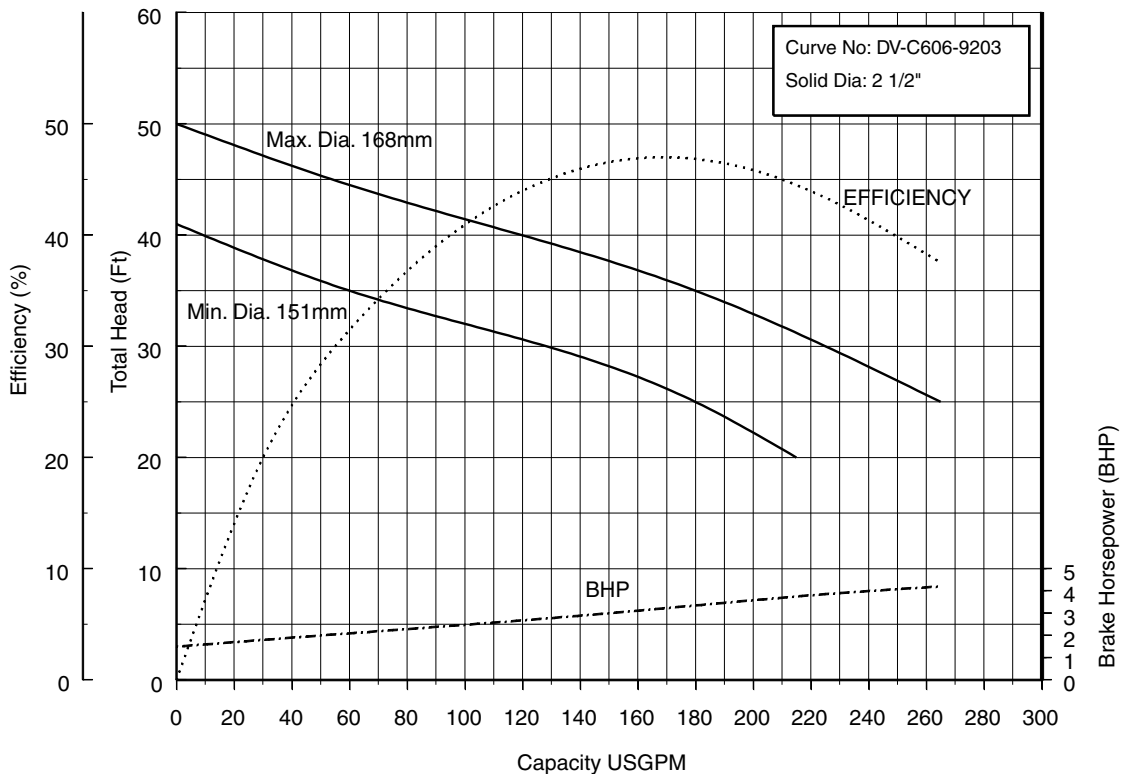

Performance Curves

Project: _____ GPM: _____ TDH: _____ EFF: _____ HP: _____ Chk'd: _____ Date: _____

100DV63.7S (5HP) Synchronous Speed: 1800 RPM

4 inch Discharge

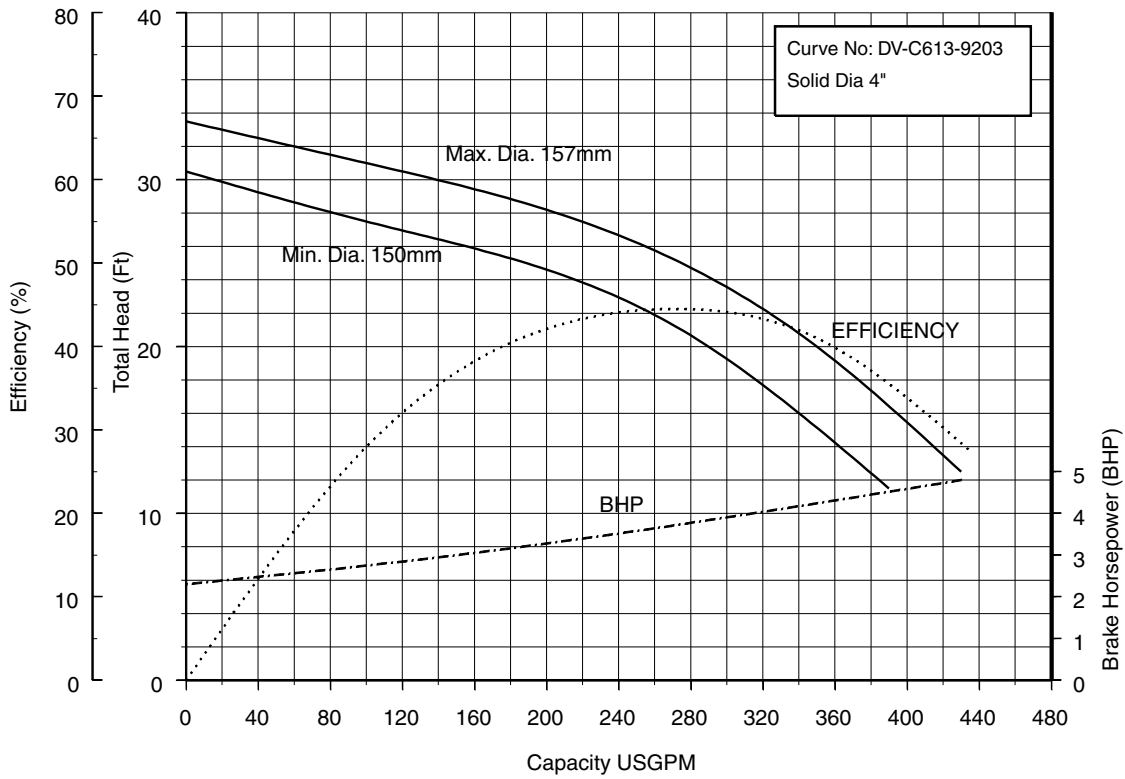

Dimensions

Project: _____ Model: _____ Chk'd: _____ Date: _____

Model DVU, Single and Three Phase

50DVU, 1 to 3HP
 80DVU, 2 to 5 HP
 100DVU, 5HP

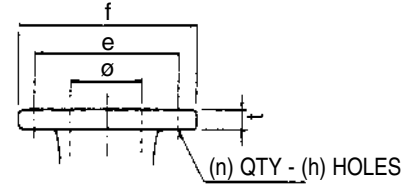
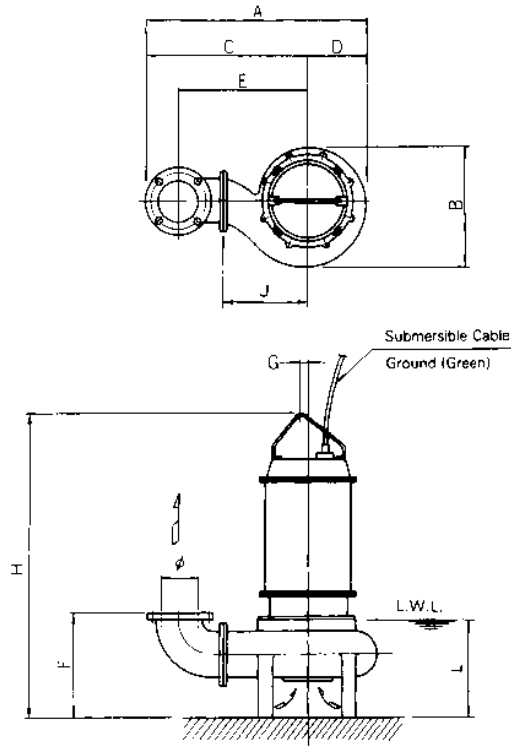

Flange (ANSI 125 PSI F.F)

inch					
Ø	e	f	t	n	h
2	4 ³ / ₄	6	5 ⁵ / ₈	4	3 ³ / ₄
3	6	7 ¹ / ₂	3 ³ / ₄	4	3 ³ / ₄
4	7 ¹ / ₂	9	1 ⁵ / ₁₆	8	3 ³ / ₄

mm					
Ø	e	f	t	n	h
50	121	152	16	4	19
80	152	191	19	4	19
100	191	229	24	8	19

Dimensions: inch

PHASE	SIZE Ø	MODEL	OUTPUT		PUMP & MOTOR										WEIGHT Lb
			KW	HP	A	B	C	D	E	F	G	H	J	L	
SINGLE	2	50DVU6.75S	0.75	1	13 ¹⁵ / ₁₆	7 ¹¹ / ₁₆	10 ³ / ₁₆	3 ⁷ / ₈	7 ¹ / ₁₆	7 ⁵ / ₁₆	1 ³ / ₁₆	22 ⁵ / ₁₆	4 ¹⁵ / ₁₆	6 ¹ / ₂	57
		50DVU61.5S	1.5	2	15 ³ / ₄	9 ³ / ₈	11 ¹ / ₁₆	4 ¹¹ / ₁₆	8 ¹ / ₁₆	7 ⁵ / ₁₆	1 ³ / ₁₆	23	5 ⁷ / ₈	6 ⁵ / ₈	86
		50DVU62.2S	2.2	3	15 ³ / ₄	9 ³ / ₈	11 ¹ / ₁₆	4 ¹¹ / ₁₆	8 ¹ / ₁₆	7 ⁵ / ₁₆	1 ³ / ₁₆	27 ³ / ₁₆	5 ⁷ / ₈	6 ⁷ / ₈	110
	3	80DVU61.5S	1.5	2	17 ¹¹ / ₁₆	8 ⁷ / ₈	13 ¹ / ₁₆	4 ¹¹ / ₁₆	9 ¹ / ₄	8 ¹³ / ₁₆	1 ³ / ₁₆	24 ⁷ / ₁₆	6 ⁵ / ₁₆	8 ¹ / ₁₆	95
		80DVCU62.2S	2.2	3	17 ¹¹ / ₁₆	8 ⁷ / ₈	13 ¹ / ₁₆	4 ¹¹ / ₁₆	9 ¹ / ₄	8 ¹³ / ₁₆	1 ³ / ₁₆	28 ⁹ / ₁₆	6 ⁵ / ₁₆	8 ⁵ / ₁₆	119
		80DVCU63.7S	3.7	5	17 ¹¹ / ₁₆	8 ⁷ / ₈	13 ¹ / ₁₆	4 ¹¹ / ₁₆	9 ¹ / ₄	8 ¹³ / ₁₆	1 ³ / ₁₆	30 ³ / ₈	6 ⁵ / ₁₆	8 ⁵ / ₁₆	139
		80DVBU62.2S	2.2	3	18 ⁹ / ₁₆	9 ¹⁵ / ₁₆	13 ⁵ / ₈	4 ¹⁵ / ₁₆	9 ¹³ / ₁₆	10	1	30 ⁷ / ₁₆	6 ⁷ / ₈	10 ³ / ₁₆	137
		80DVBU63.7S	3.7	5	18 ⁹ / ₁₆	9 ¹⁵ / ₁₆	13 ⁵ / ₈	4 ¹⁵ / ₁₆	9 ¹³ / ₁₆	10	1	32 ¹ / ₄	6 ⁷ / ₈	10 ³ / ₁₆	143
4	100DVU63.7S	3.7	5	23 ³ / ₁₆	12 ¹ / ₈	17 ¹ / ₈	6 ¹ / ₁₆	12 ⁵ / ₈	12	1	34 ⁷ / ₁₆	8 ⁷ / ₁₆	12 ³ / ₈	176	
THREE	2	50DVU6.75	0.75	1	13 ¹⁵ / ₁₆	7 ¹¹ / ₁₆	10 ¹ / ₁₆	3 ⁷ / ₈	7 ¹ / ₁₆	7 ⁵ / ₁₆	1 ³ / ₁₆	23 ¹ / ₁₆	4 ¹⁵ / ₁₆	6 ¹ / ₂	53
		50DVU61.5	1.5	2	15 ³ / ₄	9 ³ / ₈	11 ¹ / ₁₆	4 ¹¹ / ₁₆	8 ¹ / ₁₆	7 ⁵ / ₁₆	1 ³ / ₁₆	26 ³ / ₈	5 ⁷ / ₈	6 ⁵ / ₈	95
	3	80DVU61.5	1.5	2	17 ¹¹ / ₁₆	8 ⁷ / ₈	13 ¹ / ₁₆	4 ¹¹ / ₁₆	9 ¹ / ₄	8 ¹³ / ₁₆	1 ³ / ₁₆	27 ¹³ / ₁₆	6 ⁵ / ₁₆	8 ¹ / ₁₆	104

Dimensions: mm

PHASE	SIZE Ø	MODEL	OUTPUT		PUMP & MOTOR										WEIGHT kg
			KW	HP	A	B	C	D	E	F	G	H	J	L	
SINGLE	50	50DVU6.75S	0.75	1	354	195	258	98	180	185	30	567	125	165	26
		50DVU61.5S	1.5	2	400	238	281	119	205	185	20	584	150	168	39
		50DVU62.2S	2.2	3	400	238	281	119	205	185	20	690	150	175	50
	80	80DVU61.5S	1.5	2	450	225	331	119	235	224	20	620	160	204	43
		80DVCU62.2S	2.2	3	450	225	331	119	235	224	20	726	160	211	54
		80DVCU63.7S	3.7	5	450	225	331	119	235	224	20	772	160	211	63
		80DVBU62.2S	2.2	3	471	252	346	125	250	254	25	773	175	258	62
		80DVBU63.7S	3.7	5	471	252	346	125	250	254	25	819	175	258	65
100	100DVU63.7S	3.7	5	589	308	435	154	320	305	25	875	215	314	80	
THREE	50	50DVU6.75	0.75	1	354	195	256	98	180	185	30	586	125	165	24
		50DVU61.5	1.5	2	400	238	281	119	205	185	20	670	150	168	43
	80	80DVU61.5	1.5	2	450	225	331	119	235	224	20	706	160	204	47



Dimensions

Project: _____ Model: _____ Chk'd: _____ Date: _____

Model DVU, with Quick Discharge Connector, Single and Three Phase
 50DVU, 1 to 3HP

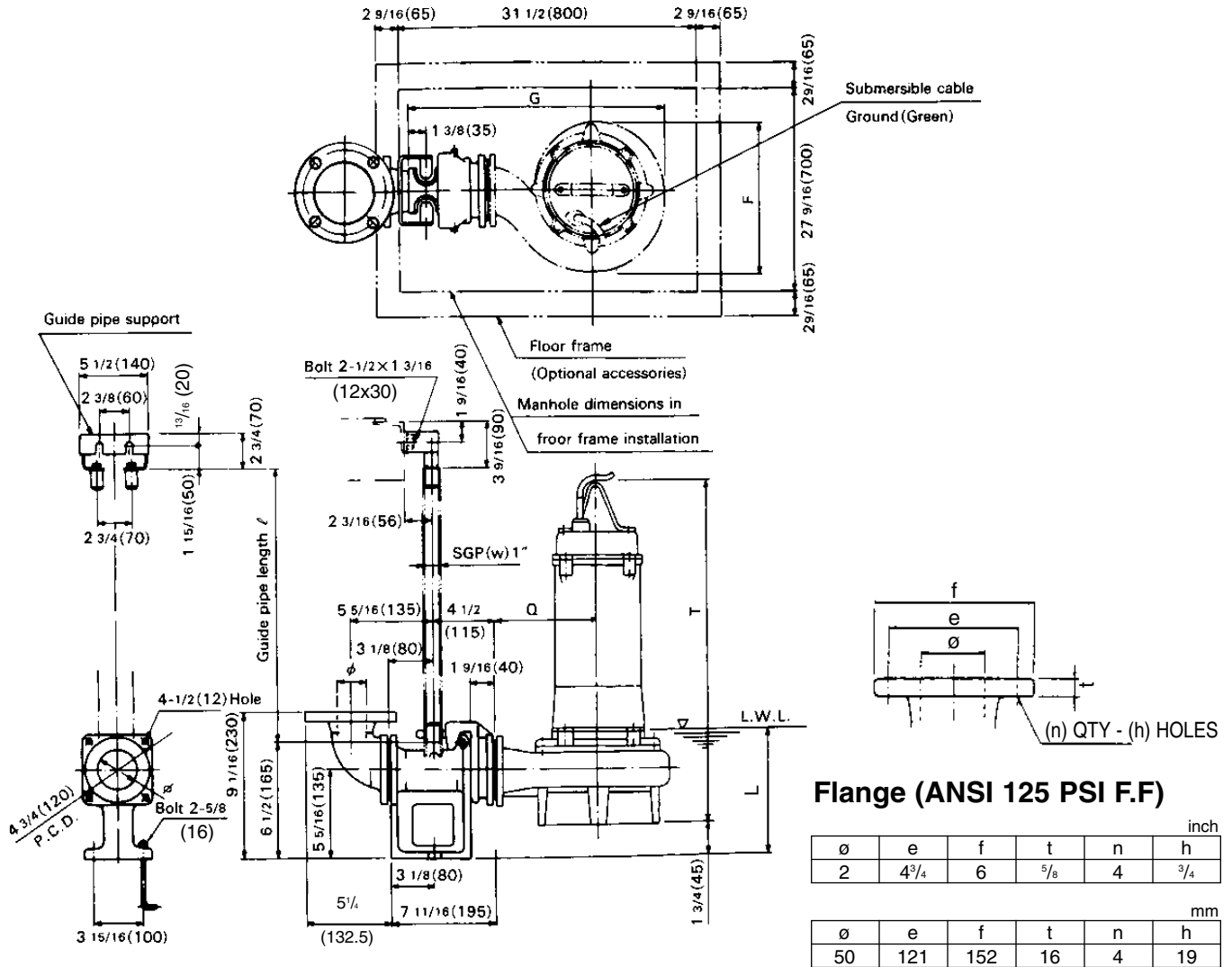

Flange (ANSI 125 PSI F.F)

inch					
ø	e	f	t	n	h
2	4 ³ / ₄	6	5 ⁵ / ₈	4	3 ³ / ₄

mm					
ø	e	f	t	n	h
50	121	152	16	4	19

Dimensions: inch

PHASE	SIZE ø	MODEL	OUTPUT		QDC MODEL	PUMP & MOTOR					WEIGHT Lb	
			kW	HP		F	G	L	Q	T	PUMP	Q.D.C.
SINGLE	2	50DVU6.75S	0.75	1	LM50	7 ¹ / ₁₆	14 ³ / ₈	8 ³ / ₄	4 ¹⁵ / ₁₆	22 ⁵ / ₁₆	57	24
		50DVU61.5S	1.5	2	LM50	8 ⁹ / ₁₆	16 ¹ / ₄	8 ³ / ₈	5 ⁷ / ₈	23	86	24
		50DVU62.2S	2.2	3	LM50	8 ⁹ / ₁₆	15 ¹ / ₈	8 ¹¹ / ₁₆	5 ⁷ / ₈	27 ⁹ / ₁₆	110	24
THREE	2	50DVU6.75	0.75	1	LM50	7 ¹ / ₁₆	14 ³ / ₈	8 ³ / ₄	4 ¹⁵ / ₁₆	23 ³ / ₁₆	53	24
		50DVU61.5	1.5	2	LM50	8 ⁹ / ₁₆	16 ¹ / ₄	8 ³ / ₈	5 ⁷ / ₈	26 ³ / ₈	95	24

Dimensions: mm

PHASE	SIZE ø	MODEL	OUTPUT		QDC MODEL	PUMP & MOTOR					WEIGHT Lb	
			kW	HP		F	G	L	Q	T	PUMP	Q.D.C.
SINGLE	2	50DVU6.75S	0.75	1	LM50	179	365	210	125	567	26	11
		50DVU61.5S	1.5	2	LM50	217	413	213	150	584	39	11
		50DVU62.2S	2.2	3	LM50	217	384	220	150	690	50	11
THREE	2	50DVU6.75	0.75	1	LM50	179	365	210	125	586	24	11
		50DVU61.5	1.5	2	LM50	217	413	213	150	670	43	11



Dimensions

Project: _____ Model: _____ Chk'd: _____ Date: _____

Model DVU, with Quick Discharge Connector, Single and Three Phase
 80DVU, 2HP
 80DVCU, 3 to 5HP
 80DVBU, 3 to 5HP

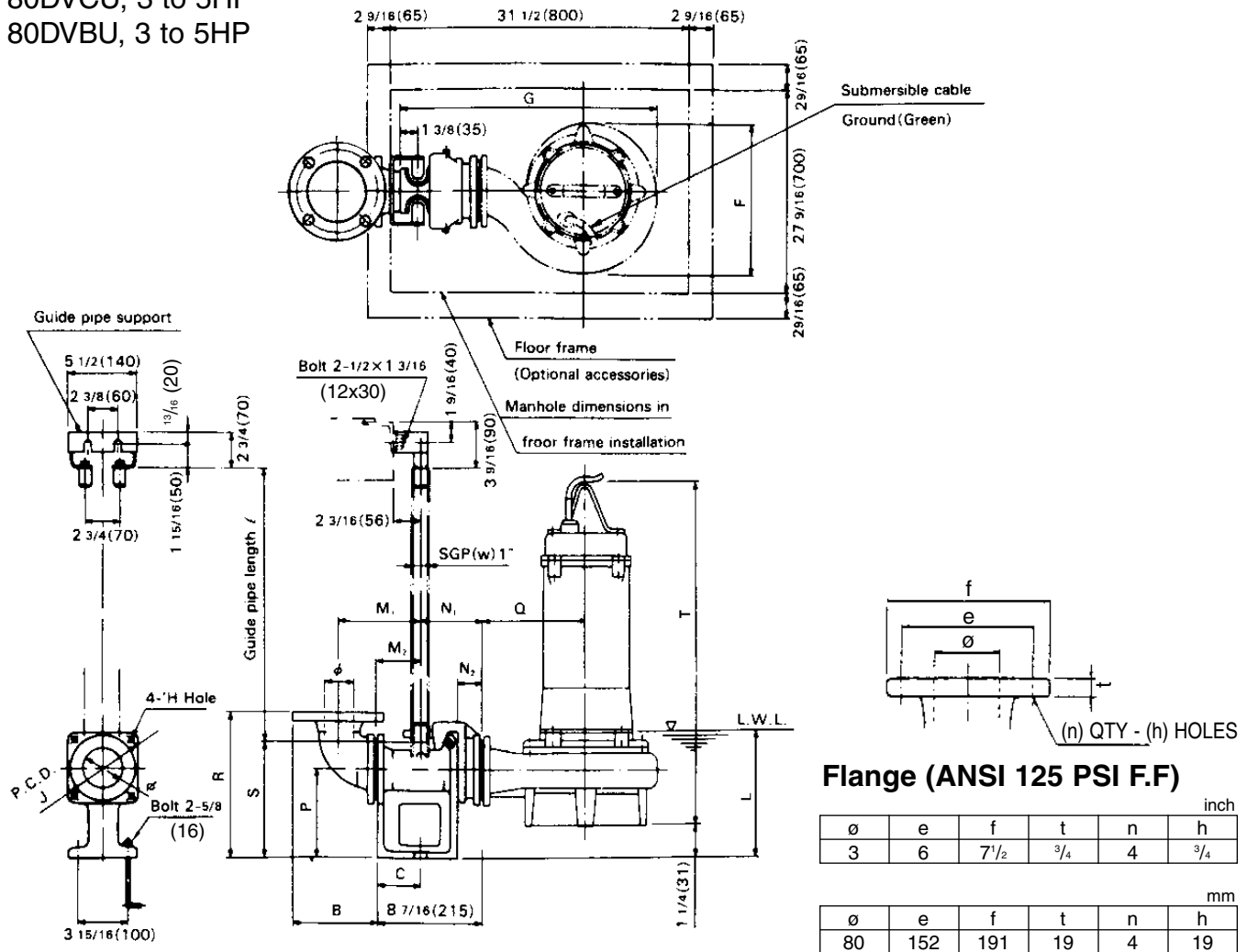

Flange (ANSI 125 PSI F.F)

inch

ø	e	f	t	n	h
3	6	7 1/2	3/4	4	3/4

mm

ø	e	f	t	n	h
80	152	191	19	4	19

Dimensions: inch

PHASE	SIZE ø	PUMP MODEL	OUTPUT KW/HP	QDC MODEL	QDC										PUMP & MOTOR					WEIGHT Lb			
					B	C	H	J	M ₁	M ₂	N ₁	N ₂	P	R	S	F	G	L	Q	T	PUMP	QDC	
SINGLE	3	80DVU61.5S	1.5	2	LM65	6	3 3/4	1/2	5 1/2	6 11/16	3 3/4	4 3/4	1 3/4	5 11/16	10 1/16	7 1/2	8 7/8	16 7/8	9 1/4	6 5/16	24 7/16	95	31
		80DVCU62.2S	2.2	3	LM65	6	3 3/4	1/2	5 1/2	6 11/16	3 3/4	4 3/4	1 3/4	5 11/16	10 1/16	7 1/2	8 7/8	16 7/8	9 1/2	6 5/16	28 9/16	119	31
		80DVCU63.7S	3.7	5	LM65	6	3 3/4	1/2	5 1/2	6 11/16	3 3/4	4 3/4	1 3/4	5 11/16	10 1/16	7 1/2	10 3/4	19	9 1/2	6 7/8	30 3/8	139	31
		80DVBU62.2S	2.2	3	LM80	6 3/8	3 9/16	9/16	6 1/8	6 1/2	3 9/16	4 15/16	1 15/16	6 7/8	11 1/4	9 9/16	9 9/16	18 1/8	11 3/8	6 7/8	30 7/16	137	37
		80DVBU63.7S	3.7	5	LM80	6 3/8	3 9/16	9/16	6 1/8	6 1/2	3 9/16	4 15/16	1 15/16	6 7/8	11 1/4	9 9/16	11 1/4	19 9/16	11 3/8	8 7/16	32 1/4	143	37
THREE	3	80DVU61.5	1.5	2	LM65	6	3 3/4	1/2	5 1/2	6 5/16	3 3/4	4 3/4	1 3/4	5 11/16	10 1/16	7 1/2	8 7/8	16 7/8	9 1/4	6 5/16	27 13/16	104	31

Dimensions: mm

PHASE	SIZE ø	PUMP MODEL	OUTPUT KW/HP	QDC MODEL	QDC										PUMP & MOTOR					WEIGHT kg			
					B	C	H	J	M ₁	M ₂	N ₁	N ₂	P	R	S	F	G	L	Q	T	PUMP	QDC	
SINGLE	80	80DVU61.5S	1.5	2	LM65	152.5	95	12	140	170	95	120	45	145	255	190	225	428	235	160	620	43	14
		80DVCU62.2S	2.2	3	LM65	152.5	95	12	140	170	95	120	45	145	255	190	225	428	242	160	726	54	14
		80DVCU63.7S	3.7	5	LM65	152.5	95	12	140	170	95	120	45	145	255	190	273	482	242	175	772	63	14
		80DVBU62.2S	2.2	3	LM80	167.5	90	15	155	165	90	125	50	175	285	230	249	460	289	175	773	62	17
		80DVBU63.7S	3.7	5	LM80	167.5	90	15	155	165	90	125	50	175	285	230	285	503	289	215	819	65	17
THREE	80	80DVU61.5	1.5	2	LM65	152.5	95	12	140	160	95	120	45	145	255	190	225	428	235	160	706	47	14



Dimensions

Project: _____ Model: _____ Chk'd: _____ Date: _____

Model DVU, with Quick Discharge Connector, Single Phase
 100DVU, 5HP

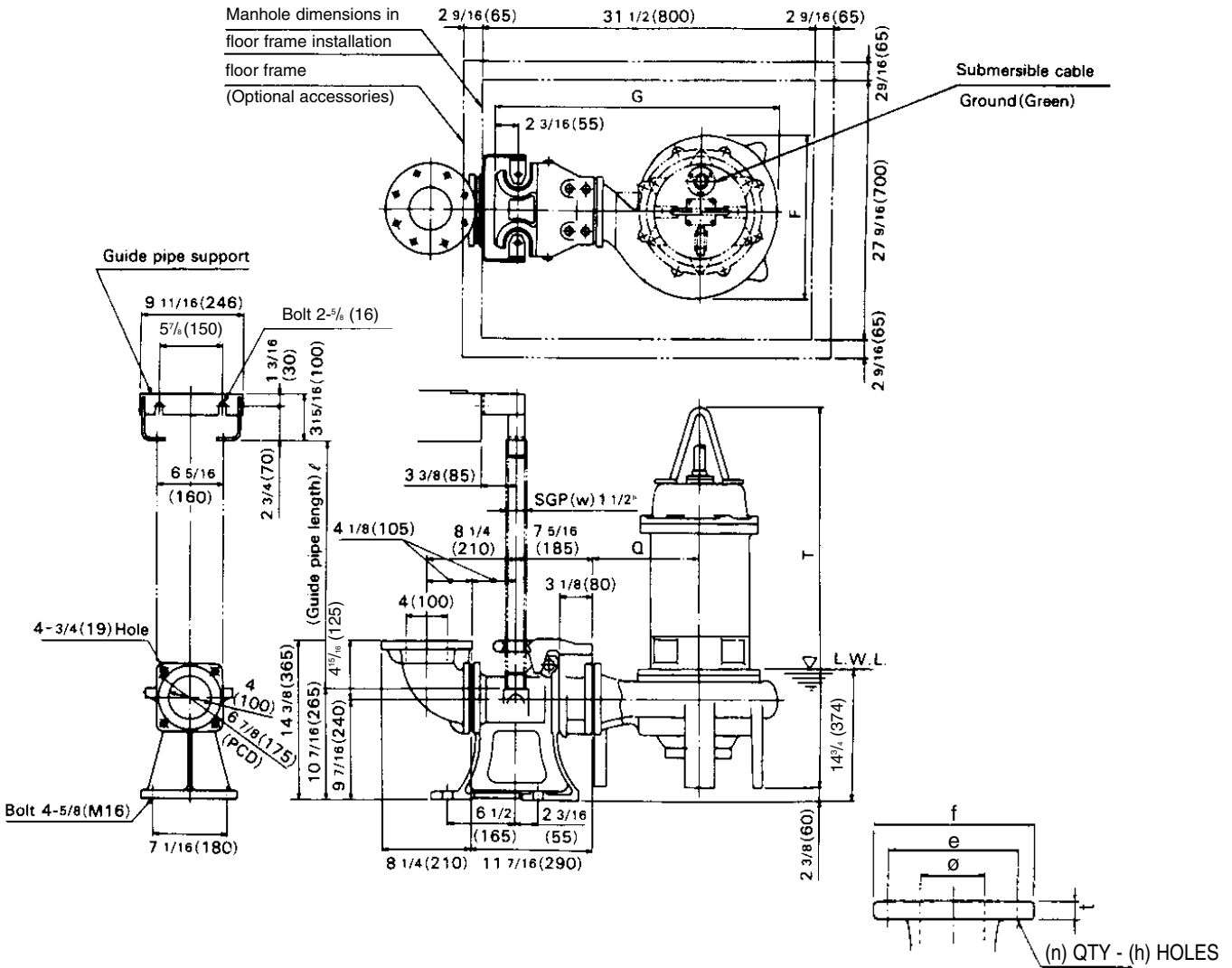

Flange (ANSI 125 PSI F.F)

inch					
ø	e	f	t	n	h
4	7 1/2	9	15/16	8	3/4

mm					
ø	e	f	t	n	h
100	191	229	24	8	19

Dimensions: inch

PHASE	SIZE ø	MODEL	OUTPUT		QDC MODEL	PUMP & MOTOR				WEIGHT Lb	
			KW	HP		F	G	Q	T	PUMP	Q.D.C.
SINGLE	4	100DVU63.7S	3.7	5	LL100	12 1/8	24	8 7/16	34 7/16	176	101

Dimensions: mm

PHASE	SIZE ø	MODEL	OUTPUT		QDC MODEL	PUMP & MOTOR				WEIGHT kg	
			KW	HP		F	G	Q	T	PUMP	Q.D.C.
SINGLE	100	100DVU63.7S	3.7	5	LL100	308	609	215	875	80	46



Sectional View

Project: _____ Model: _____ Chk'd: _____ Date: _____

Single Phase
1 to 5HP

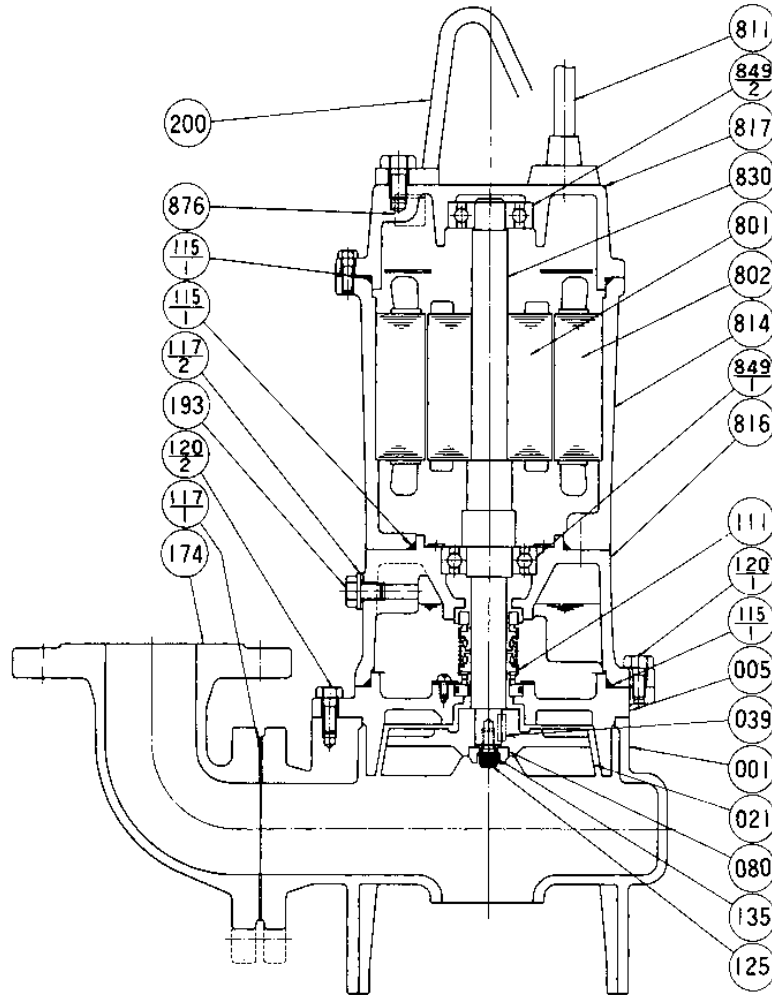

PART NO.	PART NAME	MATERIAL	ASTM, AISI CODE	NO. FOR 1 UNIT
001	CASING	CAST IRON	A48 Class 30	1
005	INTERMEDIATE CASING	CAST IRON	A48 Class 30	1
†021	IMPELLER	CAST IRON	A48 Class 30	1
039	KEY	420 STAINLESS	AISI420	1
†080	BUSHING	STEEL	A283 Grade D	1
†111	MECHANICAL SEAL	—		1 SET
†115-1	O-RING	RUBBER (NBR)		1
†115-2	O-RING	RUBBER (NBR)		1
†115-3	O-RING	RUBBER (NBR)		1
†117-1	GASKET			1
†117-2	GASKET			1
120-1	BOLT	304 STAINLESS	AISI304	4
120-2	BOLT	304 STAINLESS	AISI304	4 or 8
125	BOLT	304 STAINLESS	AISI304	1

PART NO.	PART NAME	MATERIAL	ASTM, AISI CODE	NO. FOR 1 UNIT
135	WASHER	304 STAINLESS	AISI304	1
174	DISCHARGE ELBOW	CAST IRON	A48 Class 30	1
193	OIL PLUG	316 STAINLESS	AISI316	1
200	LIFTING HANGER	STEEL	A283 Grade D	1
801	ROTOR	—		1
802	STATOR	—		1
†811	SUBMERSIBLE CABLE	—		1
814	MOTOR FRAME	CAST IRON	A48 Class 30	1
816	BRACKET	CAST IRON	A48 Class 30	1
817	BRACKET	CAST IRON	A48 Class 30	1
830	SHAFT	403 STAINLESS	AISI403	1
†849-1	BALL BEARING	—		1
†849-2	BALL BEARING	—		1
876	MOTOR PROTECTOR	—		1

Motors are purchased as a complete unit

†: Recommended spare parts



Sectional View

Project:

Model:

Chk'd:

Date:

Three Phase
1 to 2HP

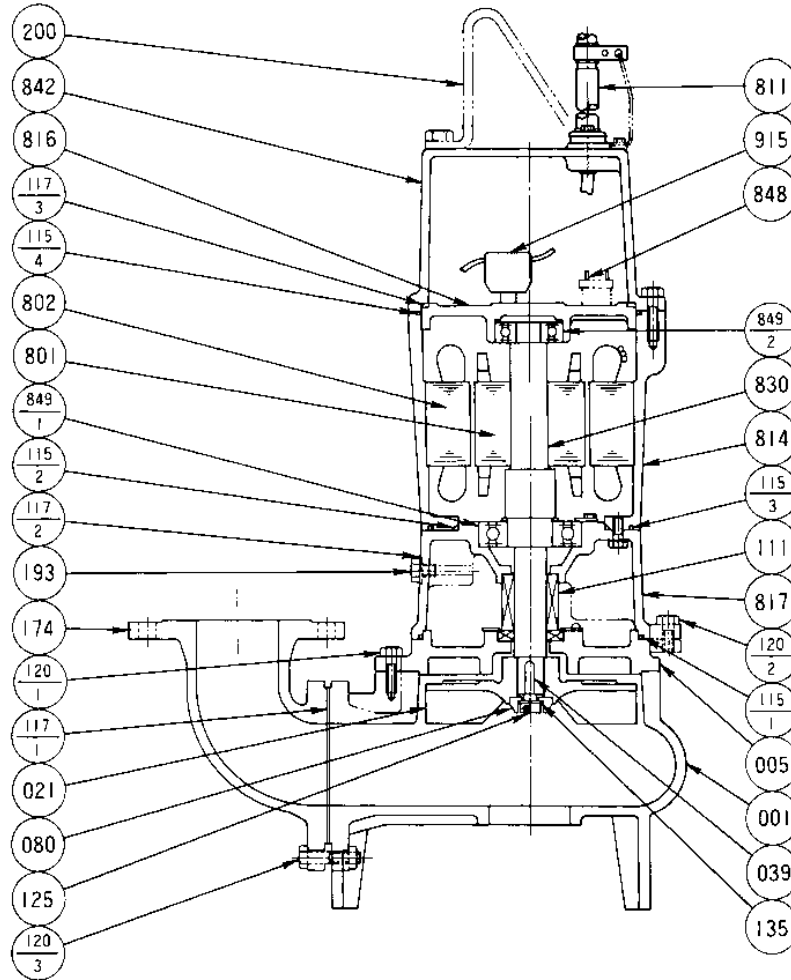

PART NO.	PART NAME	MATERIAL	ASTM, AISI CODE	NO. FOR 1 UNIT
001	CASING	CAST IRON	A48 Class 30	1
005	INTERMEDIATE CASING	CAST IRON	A48 Class 30	1
†021	IMPELLER	CAST IRON	A48 Class 30	1
039	KEY	420 STAINLESS	AISI420	1
†080	BUSHING	STEEL	A283 Grade D	1
†111	MECHANICAL SEAL	—		1 SET
†115-1	O-RING	RUBBER (NBR)		1
†115-2	O-RING	RUBBER (NBR)		1
†115-3	O-RING	RUBBER (NBR)		1
†115-4	O-RING	RUBBER (NBR)		1
†117-1	GASKET			1
†117-2	GASKET			1
†117-3	GASKET	RUBBER (NBR)		1
120-1	BOLT	304 STAINLESS	AISI304	4 or 8
120-2	BOLT	304 STAINLESS	AISI304	4
120-3	BOLT	304 STAINLESS	AISI304	4
125	BOLT	304 STAINLESS	AISI304	1

PART NO.	PART NAME	MATERIAL	ASTM, AISI CODE	NO. FOR 1 UNIT
135	WASHER	304 STAINLESS	AISI304	1
174	DISCHARGE ELBOW	CAST IRON	A48 Class 30	1
193	OIL PLUG	316 STAINLESS	AISI316	1
200	LIFTING HANGER	STEEL	A283 Grade D	1
801	ROTOR	—		1
802	STATOR	—		1
†811	SUBMERSIBLE CABLE	—		1
814	MOTOR FRAME	CAST IRON	A48 Class 30	1
816	BRACKET	CAST IRON	A48 Class 30	1
817	BRACKET	CAST IRON	A48 Class 30	1
830	SHAFT	403 STAINLESS	AISI403	1
842	MOTOR COVER	CAST IRON	A48 Class 30	1
848	MOTOR PROTECTOR	—		1
†849-1	BALL BEARING	—		1
†849-2	BALL BEARING	—		1
915	EXTERNAL TERMINAL	—		1

Motors are purchased as a complete unit
†: Recommended spare parts

